

**GOVERNING DOCUMENTS
FOR
CARRIAGE MANOR RV RESORT**

ARTICLES OF INCORPORATION
BY-LAWS
DECLARATION
ARCHITECTURAL GUIDELINE
RULES AND REGULATIONS

TABLE OF CONTENTS

ARTICLES OF INCORPORATION

ARTICLE 1

Name

1.1 Corporation Name..... 1

ARTICLE 2

Purpose of Corporation

2.1 Purpose..... 1
2.2 Governing Body for Owners 1
2.3 No Gain or Profit..... 2
2.4 Duties of Corporation 2
2.5 No Individual Incurement 4

ARTICLE 3

Place of Business

3.1 Place of Business 4

ARTICLE 4

Membership

4.1 Non-Stock Corporation..... 4
4.2 Limited Membership..... 4
4.3 Membership List..... 4
4.4 Annual Meeting..... 5

ARTICLE 5

Board of Directors and Officers

5.1 Board of Directors..... 5
5.2 Officers..... 5
5.3 Authority of Board of Directors..... 5

ARTICLE 6

Indemnity

6.1 Indemnification of Officers and Directors 5

ARTICLE 7

Amendments to Articles

7.1 Amendments to Articles..... 6

ARTICLE 8

Duration

8.1 Duration..... 6

ARTICLE 9

9.1 Declaration Controlling Document..... 6
9.2 Adoption of Amended Articles..... 6

BY-LAWS

PART 1

Name and Location

1.1 Name..... 7
1.2 Location..... 7

PART 2

Definitions

2.1 Association..... 7
2.2 Property..... 7
2.3 Common Areas..... 7
2.4 Lot..... 7
2.5 Owner..... 7
2.6 Declaration..... 7
2.7 Member..... 7

PART 3

Meeting of Members

3.1 Annual Meetings..... 8
3.2 Special Meetings..... 8
3.3 Notice of Annual and Special Meetings..... 8
3.4 Quorum..... 8

PART 4

Board of Directors

4.1 Number..... 8
4.2 Term of Office..... 8
4.3 Removal; Vacancy..... 9
4.4 Compensation..... 9
4.5 Action Taken Without a Meeting..... 9
4.6 Election..... 9

PART 5

Meetings of Directors

5.1 Regular Meetings..... 9
5.2 Special Meetings..... 9
5.3 Quorum..... 10
5.4 Executive Session..... 10

PART 6	
<u>Powers and Duties of the Board of Directors</u>	
6.1	Powers 10
6.2	Limitations..... 10
6.3	Duties..... 11
PART 7	
<u>Officers and Their Duties</u>	
7.1	Enumeration of Offices 11
7.2	Election of Officers 11
7.3	Term..... 11
7.4	Special Appointments 11
7.5	Resignation and Removal 11
7.6	Vacancies..... 12
7.7	Multiple Offices 12
7.8	Duties..... 12
PART 8	
<u>Committees</u>	
8.1	Committees 13
PART 9	
<u>Books and Records</u>	
9.1	Books and Records 13
PART 10	
<u>Amendments</u>	
10.1	Passage of Amendments 13
10.2	Conflict..... 13
PART 11	
<u>Miscellaneous</u>	
11.1	Fiscal Year 13
PART 12	
<u>Common Area Development Process</u>	
12.1	Common Area Development Process 13
DECLARATION OF CC&R'S	
PART 1	
<u>Definitions</u>	
1.1	Articles 16
1.2	Assessments..... 16
1.3	Association 17
1.4	Association Rules..... 17
1.5	Board 17

1.6	Bylaws	17
1.7	Commercial Truck.....	17
1.8	Common Areas	17
1.9	Common Expenses.....	17
1.10	Improvement.....	17
1.11	Lot.....	17
1.12	Member.....	17
1.13	Owner.....	18
1.14	Park Model.....	18
1.15	Property.....	18
1.16	Purchaser	18
1.17	Recreational Vehicles.....	18
1.18	Resident Member	18
1.19	Single Family.....	18
1.20	Subdivision Map or Subdivision Plat.....	18
1.21	Tract.....	18
1.22	Visible from Neighboring Property	19
1.23	Manufactured Home	19
1.24	Factory Built Building.....	19
1.25	Mobile Home	19

PART 2

Common Areas

2.1	Owner's Right of Enjoyment.....	19
2.2	Transfer of Use of Common Areas	19
2.3	Conveyance of Common Areas.....	20
2.4	Partition of Common Areas.....	20
2.5	Abandonment or Failure to Use Common Areas	20

PART 3

Use Restrictions

3.1	Use Limited to Recreational Vehicles and Park Models and Manufactured	20
3.2	Commercial Uses Prohibited	20
3.3	Parking on Lots.....	20
3.4	Parking on Common Areas.....	21
3.5	Additional Parking Restrictions.....	21
3.6	Vehicle Appearance	21
3.7	Antennas	21
3.8	Utility Service.....	22
3.9	Lot Maintenance	22
3.10	Trash Containers; Collections; Incinerators	22
3.11	Overhangs.....	22
3.12	Machinery and Equipment.....	22
3.13	Restriction on Further Subdivision.....	23
3.14	Signs.....	23
3.15	Future Utility Installations	23

3.16	Offensive Activities and Nuisances	23
3.17	Noise	24
3.18	Laundry Facilities.....	24
3.19	Mineral Exploration.....	24
3.20	Maintenance of Drainage Facilities.....	24
3.21	Lighting.....	24
3.22	Temporary Structures	24
3.23	Animals	24
3.24	Air Conditioning and Other Systems.....	25
3.25	Rugs.....	25
3.26	Reflective Materials	25
3.27	Improvements.....	25
3.28	Propane Tanks.....	25
3.29	Age Restriction	26
3.30	Solicitation.....	26
3.31	Age of Recreational Vehicles and Park Models.....	26
3.32	Required Landscaping.....	26
3.33	Utility Facility Maintenance.....	26
3.34	Promulgation of Rules.....	27
3.35	Grand-fathered Conditions.....	27
3.36	Excess Lots.....	27
3.37	Transfer of Property.....	27
3.38	Leasing Limitations	27

PART 4

Easements

4.1	Right of Inspection	28
4.2	Lot Setbacks	28
4.3	Utility Easements.....	28
4.4	Drainage Easement.....	28
4.5	Easement for Encroachments.....	28
4.6	Entry to Install and Maintain Landscaping.....	29

PART 5

Application of Declaration to Guests and Others

5.1	Guests Subject to Declaration.....	29
5.2	Declaration Incorporated in Lease.....	29
5.3	Notice to Lessee	29
5.4	Action by Association.....	29
5.5	Cost of Action by Association	30

PART 6

Association Organization and Membership

6.1	Formation and Organization	30
6.2	Membership	30
6.3	Transfer of Membership	30

6.4	Membership Records and Voting.....	30
6.5	Meetings	31
6.6	Quorum.....	31
6.7	Indemnification.....	31

PART 7

Powers of the Association

7.1	Powers and Authority of the Association.....	32
7.2	Management	34
7.3	Emergency Powers	34
7.4	Member Actions	34

PART 8

Duties of the Association

8.1	Duties.....	34
8.2	Accounting.....	35

PART 9

Covenants for Assessments

9.1	Creation of the Lien and Personal Obligation of Assessments.....	36
9.2	Use of Assessments.....	36
9.3	Regular Annual Assessments	36
9.4	Insufficient or Excessive Assessments.....	37
9.5	Default Minimum Assessment	37
9.6	Capital Improvement Fund	37
9.7	Working Capital Fund	38
9.8	Supplementary Assessments	38
9.9	Special Assessments	38
9.10	Inadequate Assessments and Increase in Assessments.....	38
9.11	Uniform Rate of Assessment	39
9.12	Assessment Status Certificates.....	39
9.13	Interest on Delinquent Assessments.....	39
9.14	Effect of Nonpayment of Assessments	39
9.15	Enforcement by Suit	39
9.16	Action for Future Assessments.....	39
9.17	Evidence of Lien	39
9.18	Priority of Lien.....	40
9.19	Enforcement of Lien	40

PART 10

Architectural Review

10.1	Obligation to Submit Exterior Plans for Approval.....	40
10.2	Submission of Plans.....	41
10.3	Standard for Approval	41
10.4	Delayed Approval.....	41
10.5	Waiver.....	41

10.6	Liability	41
10.7	Changes to Plans	42

PART 11

Insurance

11.1	Terms	42
11.2	Additional Insurance.....	42
11.3	Premiums and Proceeds	42

PART 12

Enforcement

12.1	Rights of Enforcement	42
12.2	Suspension of Voting and Common Areas Rights.....	43
12.3	Recorded Notice of Violation.....	43
12.4	Contents of Notice	43
12.5	Release of Notice.....	43
12.6	Violations and Nuisance.....	44
12.7	Self Help	44
12.8	Covenants Cumulative	44
12.9	Attorneys' Fees.....	44

PART 13

Right of First Refusal

13.1	Ownership Subject to Right of Refusal	44
13.2	Sales Only After Bona Fide Offers	44
13.3	Notice of Offer.....	44
13.4	Acceptance by Association	45
13.5	Rejection by Association	45
13.6	Closing of Sale to Association	45
13.7	Association Authority	45
13.8	Lease-Purchase Agreements.....	45

PART 14

General Provisions

14.1	Purposes of Declaration	46
14.2	Running with the Land	46
14.3	Severability.....	46
14.4	Construction.....	46
14.5	Term.....	46
14.6	Amendments.....	46
14.7	Singular Includes Plural.....	46
14.8	Perpetuities and Other Invalidity	46
14.9	Violation of Law	47
14.10	Delivery of Notices and Documents	47
14.11	Covenant by Owners	47

DESIGN GUIDELINES

PART 1

Purpose

1.1 Declaration Authority49
1.2 Supplement Declaration49
1.3 Deviations49
1.4 Amendment to Guidelines.....49
1.5 Code Compliance50
1.6 Carriage Manor Limitations.....50
1.7 Insurance50
1.8 Permits.....50

PART 2

Permit Procedure

2.1 Required Forms.....50
2.2 Submission Sequence.....50

PART 3

Schedule Requirements

3.1 Time Limits51
3.2 Permit Posting.....51
3.3 Non Compliance Levy of Fine51
3.4 Levy of Fines51

PART 4

Construction Requirements

4.1 Paving and Grading.....52
4.2 Setbacks - Easements.....52
4.3 Placement of Motor Homes, 5th Wheels & Trailers53
4.4 Roofing.....53
4.5 Siding.....53
4.6 Skirting.....53
4.7 Steps.....54
4.7.1 Driveways54
4.8 Park Model Removal54
4.9 Park Model Home54
4.10 Manufactured Housing.....55
4.11 Utilities.....57
4.12 Awnings.....57
4.13 Storage Structures.....58
4.13.1 Vinyl Storage Sheds/Chests.....59
4.14 Raised Decks59
4.15 Arizona Room (Accessory Room)59
4.16 Landscape Guidelines60
4.17 Trellises, Hedges & Lattice Work.....62
4.18 Drip System62

4.19	Lot Line Fences.....	62
4.20	Landscape Lighting.....	63
4.21	Barbecue.....	63
4.22	Hot Tubs	63
4.23	Exemptions.....	63
	Exhibit A-1.....	64
	Exhibit A-2.....	65
	Exhibit B.....	66
	Exhibit C & D.....	67
	Exhibit E.....	68
	Exhibit F.....	69
	Exhibit G.....	70
	Exhibit H.....	71
	Exhibit I.....	72
	Exhibit J.....	73
	Exhibit K.....	74

RULES AND REGULATIONS

PART 1

Definitions

1.1	Resident.....	76
1.2	Owner.....	76
1.3	Guest.....	76
1.4	Non-Member Resident.....	76
1.5	Renter.....	76
1.6	Child/Children.....	76
1.7	Age.....	76
1.8	Residence Vehicles.....	76
1.9	Common Areas	77

PART 2

Decorum

2.1	Quiet Hours	77
2.2	Common Areas	77
2.3	Smoking.....	77
2.4	Attire.....	77
2.5	Vehicles on Sidewalks.....	77
2.6	Children	77

PART 3

General Information

3.1	Guest Registration.....	77
3.2	Extended Absences.....	77
3.3	Messages	77
3.4	Mail.....	77
3.5	Posted Rules.....	77

3.6	Solicitation.....	78
3.7	Emergencies.....	78

PART 4

Residence Vehicles

4.1	Approval.....	78
4.2	Recreational Vehicles.....	78
4.3	Skirting.....	78
4.4	Prohibited Vehicles.....	78
4.5	Placement	78
4.6	Hook-Ups.....	79
4.7	Prohibited Lines and Ropes	79
4.8	Wheel Covers.....	79
4.9	Recreational Vehicle.....	79

PART 5

Transportation Vehicles and Parking

5.1	Passenger Cars	79
5.2	Designated Parking.....	79
5.3	Visitor Parking.....	79
5.4	Prohibited Vehicles.....	79
5.5	Special Use Parking Permits	80
5.6	Patriot's Park Parking	80
5.7	Wheel Covers.....	80
5.8	Bicycles	81

PART 6

Vehicles and Traffic

6.1	Definitions	81
6.2	Privilege to Operate.....	81
6.3	Careless Driving.....	81
6.4	Owner Permitting Illegal Operation	81
6.5	Parking.....	81
6.6	Speed Limit.....	82
6.7	Stop.....	82
6.8	Vehicle Lighting	82
6.9	Yield Right of Way	82
6.10	Repairs.....	82
6.11	Vehicle Registration	82
6.12	RV Storage	82
6.13	Voluntary Compliance	82
6.14	Enforcement and Adjudication	83

PART 7

Name Badge

7.1	Name Badges Provided	83
7.2	Name Badge Wearing.....	83

PART 8
Architectural Modification Permits

8.1	External Changes.....	83
8.2	Applications	83
8.2.1	City Permits.....	83
8.3	Prior Approval.....	84
8.4	Dust Control	84

PART 9
Setbacks and Easements

9.1	Setbacks.....	84
9.2	Prohibited Uses	84
9.3	Damages	84
9.4	Removal.....	84

PART 10
Pets

10.1	Introduction.....	85
10.2	Definitions	85
10.3	Animal Numbers.....	85
10.4	Registration.....	85
10.5	Animals at Large	85
10.6	Common Areas	85
10.7	Waste.....	85
10.8	Dog Park and Patriots Park Regulations.....	86
10.9	Animal Prohibitions	86
10.10	Penalties	86

PART 11
Swimming Pool Area Rules

11.1	Residents and Guests Responsibilities.....	87
11.2	Name Badges	87
11.3	Showers.....	87
11.4	Lotions	87
11.5	Running	87
11.6	Glass Containers	87
11.7	Pets.....	87
11.8	Children	87
11.9	Swim Wear.....	87
11.10	Jacuzzi.....	87
11.11	Smoking.....	87
11.12	Radios.....	87
11.13	Items For Use In Pool	87

PART 12
Miscellaneous

12.1	Lot Numbers	88
12.2	Antennas	88
12.3	Businesses	88
12.4	Lot Maintenance	88
12.5	Patio and Deck Use.....	88
12.6	Private Property	88
12.7	Patio Storage	88
12.8	Offensive Activity	88
12.9	Signs.....	89
12.10	Exterior Speakers.....	89
12.11	Lighting.....	89
12.12	Clotheslines	89
12.13	Reflective Materials	89
12.14	Contractor Insurance	89
12.15	Contractors & Owners Hours of Work.....	89
12.16	Construction Trash	90
12.17	Charge to Owners for Individual Maintenance Services.....	90
12.18	Citrus Trees	90
12.19	Rental Properties.....	91

PART 13
Activities

13.1	Commercial Use	91
13.2	Profits	91
13.3	Nuisance	91
13.4	Patio Sales	91

PART 14
Resort Employees

14.1	Employee Tasks	91
14.2	Employee Abuse.....	91

PART 15
Enforcement

15.1	CC&R's.....	92
15.2	Fine Assessments	92

PART 16
Committees

16.1	Committees	94
------	------------------	----

**AMENDED AND RESTATED
ARTICLES OF INCORPORATION OF
CARRIAGE MANOR RV RESORT ASSOCIATION, INC.**

Pursuant to Section 10-1033 *et seq.* of the Arizona Revised Statutes, the Articles of Incorporation of Carriage Manor RV Resort Association, Inc. are hereby amended and restated in their entirety. These amended and restated Articles of Incorporation correctly set forth the provisions of the Articles of Incorporation, as amended, and these amended and restated Articles of Incorporation supersede the original articles of incorporation and all amendments to the original Articles of Incorporation.

**ARTICLE 1
Name**

- 1.1 Corporation Name. The name of this Corporation shall be Carriage Manor RV Resort Association, Inc., an Arizona non-profit corporation (sometimes referred to as the "Corporation" or the "Association").

**ARTICLE 2
Purpose of Corporation**

- 2.1 Purpose. The purpose for which this Corporation is formed is to serve as the governing body for every Owner of a Lot as those terms are defined in that certain *Declaration of Covenants, Conditions and Restrictions for Carriage Manor RV Resort*, as recorded in Document 84-307623, records of Maricopa County, Arizona, and all amendments thereto (hereinafter referred to as the "Declaration"). In furtherance of, and in order for the acquisition, construction, management, maintenance, and care of Association property and may transact any and all lawful business for which non-profit corporations may be incorporated under the laws of the State of Arizona, as they may be amended from time to time in furtherance of such purpose. It is intended that the corporation be a "residential real estate management association" within the meaning of Section 528 of the Internal Revenue Code of 1986, as amended.
- 2.2 Governing Body for Owners. As provided in and pursuant to the, Declaration, the character of the business or activity which this Corporation initially intends to conduct in this State is, to the extent permitted by applicable law, to serve as the governing body for all of the Owners of Lots for the maintenance, report, replacement, administration and operation of the Common Areas, as that term is defined in the Declaration, and to perform such duties and functions, and to exercise such rights, as are given and assigned to it by said Declaration as the same may be amended from time to time in furtherance thereof.

- 2.3 No Gain or Profit. This Corporation does not contemplate securing gain or profit to the members thereof and the members shall have no individual interest in the profits of the Corporation, if any.
- 2.4 Duties of Corporation. In the conduct of its business, the purpose of this Corporation, to the extent authorized by its Board of Directors and in accordance with the provisions of the Declaration, shall be to do all things consistent with its stated purpose set forth in Paragraph 2.1 that a non-profit corporation might do under the laws of the State of Arizona, including but not limited to the following:
- A. To accept such properties, improvements, rights and interest as may be conveyed, leased, assigned or transferred to this Corporation and to assume such obligations and duties as may be contained in any lease assigned or transferred to this Corporation;
 - B. To administer, maintain and otherwise manage all of the Common Areas and all facilities, improvements and landscaping thereon, and all property acquired by the Corporation including all facilities, structures, buildings, landscaping and other improvements and personality located thereon and owned by the Corporation; to pay all taxes and assessments, if any, which may properly be levied against the Property (as that term is defined in the Declaration) and become the obligation of the Corporation to pay; to repair, rehabilitate and restore the Property; to insure the Property against such risks as the Board of Directors shall determine; to levy and collect assessments for dues, taxes, maintenance and operating charges, and all other charges incurred by the Corporation in operating the Property, as the Board of Directors shall determine in accordance with the Declaration and the Bylaws of this Corporation (said Bylaws being hereinafter referred to as the "Bylaws"); and to impose liens against Lots within the Property to secure the payment of obligations due from the Owners, and to collect, sue, foreclose or otherwise enforce, compromise, release, satisfy and discharge such obligations, demands and all liens in accordance with the Declaration and the Bylaws;
 - C. To do all things necessary to carry out and enforce the terms and provisions of the Declaration, and to do all things and acts, including the payment of all charges and expenses incurred by the Corporation in operating the Property, which in the sole discretion of its Board of Directors shall be deemed to be in the best interest of the members of this Corporation or for the peace, comfort, safety or general welfare of the members of this Corporation, all in accordance with the Declaration;
 - D. To enter into management agreements with third parties, authorizing such parties to carry on any activities which might legally be carried on by the Corporation and delegated by the Corporation to third parties;
 - E. To develop, construct, purchase, lease, own, improve, maintain, operate and hold real and personal property of every kind and

- description as is reasonably necessary for the objects of the Corporation; to sell, convey and lease such property; and to mortgage, assign and pledge or otherwise encumber such property;
- F. To borrow money and to issue notes, bonds and other evidences of indebtedness in furtherance of any or all of the objects and purposes of this Corporation and to secure the same by mortgage, trust deed, pledge or other lien on or security interest in property of this Corporation;
 - G. To enter into, perform and carry out leases and contracts of any kind necessary to, in connection with or incidental to the accomplishment of any one or more of the objects and purposes of this Corporation;
 - H. To lend or invest its working capital and reserves with or without security;
 - I. To act as surety, indemnitor or guarantor, agent, trustee, broker or in any other capacity when appropriate to the fulfillment and furtherance of its objects and purposes;
 - J. To obtain, as necessary, for the benefit of all of the Common Areas, all water, sewage, gas and electric services and refuse collections; and to grant easements when necessary for utilities, sewer facilities and cable television over any portion of the Common Areas;
 - K. To establish and maintain working capital and capital improvement funds in amounts to be determined by the Board of Directors;
 - L. To adopt, amend and repeal such rules and regulations as the Corporation may deem reasonable;
 - M. To do all other acts and things authorized in the Declaration but not explicitly set out above;
 - N. To sue and be sued;
 - O. To enter into agreements with other owners' associations to share the use and expenses of property owned by this Corporation or by the other associations;
 - P. To make refunds of excess payments or charges to members as provided for in the Declaration;
 - Q. In general to do and perform such acts and things and to transact such business in connection with the foregoing objects and purposes as may be necessary, required and permissible under Chapter 5, Title 10, Arizona Revised Statutes.
 - R. To annually elect, if it deems such an election is in the best interests of the Corporation, as provided in §528 of the Internal Revenue Code and the Treasury Regulations relating thereto, tax treatment pursuant to the provisions of such section.

- 2.5 No Individual Incurement. No part of the net earnings of this Corporation shall inure (other than by acquiring, constructing or providing management, maintenance and care of Association property, and other than by a rebate of excess membership dues, fees, or assessments) to the benefit of any member, owner, director or other individual. The amount of earnings shall not be taken into account in any manner for the purpose of determining whether there should be a refund or the amount of any refund.

ARTICLE 3 **Place of Business**

- 3.1 Place of Business. The initial, principal and known place of business of this Corporation shall be located at 7750 East Broadway, Mesa, Arizona 85208.

ARTICLE 4 **Membership**

- 4.1 Non-Stock Corporation. The Corporation shall be a non-stock corporation and shall be owned by its members, and no dividends or pecuniary profits shall be paid to its members.
- 4.2 Limited Membership. Membership in the Corporation shall be limited to the Owners of Lots, as such is defined in the Declaration. The foregoing shall not include persons or entities who hold an interest in a Lot or all or any portion of the Property merely as security for the performance of an obligation. An Owner of a Lot shall automatically be a member of the Corporation and shall remain a member of the Corporation until such time as his ownership ceases for any reason, at which time his membership in the Corporation shall automatically cease. The membership of an Owner shall be appurtenant to and may not be separated from the fee ownership of any Lot within the Property which is subject to assessment by the Corporation.
- 4.3 Membership List. Membership shall in all cases be evidenced by an official list of said members, which list shall be kept by the Secretary of the Corporation. The membership held by any Owner shall not be transferred, pledged, assigned or alienated in any way, except that upon the conveyance of said Owner's Lot within the Property, and then only to the purchaser of such Lot. Any attempt to make a prohibited transfer is void and will not be reflected upon the books and records of the Corporation.

- 4.4 Annual Meeting. An annual meeting of the Members of this Corporation shall be held as provided in the Bylaws of the Corporation. Any member or members representing at least fifty percent (50%) of the voting power of the Corporation, who shall be present in person or by proxy, at a meeting duly called shall constitute a quorum. Votes cast by absentee ballot or other form of delivery, including the use of e-mail, fax delivery, are valid for the purpose of establishing a quorum. (Revised 02/15/2017 AGM)

ARTICLE 5

Board of Directors and Officers

- 5.1 Board of Directors. The business and affairs of this Corporation shall be conducted by a Board of Directors. The Board of Directors shall consist of not less than five (5) nor more than seven (7) directors. (Revised 02/26/2020 AGM)
- 5.2 Officers. The officers of this Corporation shall be a President, a Vice President, a Secretary, a Treasurer, and such additional officers as the Board of Directors may deem necessary, who shall be elected by the Board of Directors at its annual meeting, or at a special meeting called for that purpose, if no annual meeting is held. The officers elected shall hold office until the next annual meeting of the Board of Directors or until their successors are elected and qualified, but shall be subject to removal by the Board of Directors at any time.
- 5.3 Authority of Board of Directors. The Board of Directors shall have the power to sell, assign, lease, transfer, convey, dispose of or encumber any of the Property or fixtures of the Association; to fill vacancies occurring in the Board of Directors; to elect officers, agents and committees (with such members, powers and authority as the Board of Directors may confer), and to exercise on behalf of the Corporation, directly or through its agents and officers to the extent permitted by law, the powers of the Corporation in accordance with the Statutes of the State of Arizona, as amended from time to time, these Articles of Incorporation, the Bylaws and the Declaration.

ARTICLE 6

Indemnity

- 6.1 Indemnification of Officers and Directors. Subject to the further provisions hereof, the Corporation shall indemnify any and all of its directors, officers, former directors and former officers, against all expense incurred by them and each of them, including but not limited to legal fees, judgments and penalties which may be incurred, rendered or levied in any legal action brought against any of them for or on account of any action or omission alleged to have been committed while acting within the scope of his or her duties as director or officer of the

Corporation. Whenever any director, officer, former director or former officer shall report to the President of the Corporation that he has incurred or may incur expenses, including but not limited to legal fees, judgments and penalties in a legal action brought or about to be brought against him for or on account of any action or omission alleged to have been committed by him while acting within the scope of his or her duties as a director or officer of the Corporation, the Board of Directors shall, at its next regular or at a special meeting held within a reasonable time thereafter, determine in good faith whether, in regard to the matter involved in the action or contemplated action, such person acted, failed to act, or refused to act willfully, with gross negligence or with fraudulent or criminal intent. If the Board of Directors determines in good faith that such person did not act, failed to act, or refused to act willfully or with gross negligence or with fraudulent or criminal intent in regard to the matter involved in the action or contemplated action, indemnification shall be mandatory and shall be automatically extended as specified herein, and as provided for A.R.S. §10-1005, provided, however, that no such indemnification shall be available with respect to liabilities under the Securities Act of 1933, and provided further, that the Corporation shall have the right to refuse indemnification in any instance in which the person to whom indemnification would otherwise have been applicable shall have unreasonably refused to permit the Corporation, at its own expense and counsel of its own choosing, to defend him in the action.

ARTICLE 7 **Amendments to Articles**

- 7.1 Amendments to Articles. These Articles may be amended, at a regular or special meeting of the members, if at least sixty percent (60%) of Members casting valid ballots cast affirmative votes for adoption of the amended Articles. (Revised 02/15/2005)

ARTICLE 8 **Duration**

- 8.1 Duration. The period of duration of this Corporation shall be perpetual.

ARTICLE 9

- 9.1 Declaration Controlling Document. In the event of any conflict between these Articles of Incorporation and the Declaration, the provisions of the Declaration shall control.
- 9.2 Adoption of Amended Articles. These Amended and Restated Articles of Incorporation have been adopted by a duly held vote of in excess of seventy percent (70%) of the Members of the Association.

**AMENDED AND RESTATED BYLAWS
OF
CARRIAGE MANOR RV RESORT ASSOCIATION, INC.**

**PART 1
Name and Location**

- 1.1 Name. The name of the corporation is Carriage Manor RV Resort Association, Inc., hereinafter referred to as the “Association.”
- 1.2 Location. The principal office of the Association shall be located at 7750 East Broadway, Mesa, Arizona 85208, but meetings of members and directors may be held at such places within the State of Arizona, County of Maricopa, as may be designated by the Board of Directors.

**PART 2
Definitions**

- 2.1 Association. Association shall mean and refer to Carriage Manor RV Resort Association, Inc., its successors and assigns.
- 2.2 Property. Property shall mean and refer to that certain real property described in the Declaration and such additions thereto as may hereafter be brought within the jurisdiction of the Association.
- 2.3 Common Areas. Common Areas shall mean all real property owned by the Association for the common use and enjoyment of the Owners.
- 2.4 Lot. Lot shall mean and refer to any plot of land shown upon any recorded subdivision map of the Property with the exception of the Common Areas.
- 2.5 Owner. Owner shall mean and refer to the record owner, whether one or more persons or entities, of the fee simple title to any Lot which is a part of the Property, including contract sellers, but excluding those having such interest merely as security for the performance of an obligation.
- 2.6 Declaration. Declaration shall mean and refer to the Declaration of Covenants, Conditions and Restrictions of Carriage Manor RV Resort, as amended or restated from time to time, which is recorded in the Maricopa County Recorder's office.
- 2.7 Member. Member shall mean and refer to those persons entitled to membership as provided in the Declaration.

PART 3
Meeting of Members

- 3.1 **Annual Meetings.** An Annual meeting of the Members shall be held in the month of February in each year, on a date and at a time determined in each case by the Board of Directors. *(Revised 02/15/2005 AGM)*
- 3.2 **Special Meetings.** Special meetings of the members may be called at any time by the President or by the Board of Directors. Any member or group of members may request that a special meeting be called by the Board of Directors to consider issues of importance and urgency to such member or group of members. Upon written request of members who are entitled to vote at least thirty-three percent (33%) of all of the votes of the Association, the Board of Directors shall call a special meeting. A special meeting called at the request of members may only be held during the time period from November 1st through March 31st.
- 3.3 **Notice of Annual and Special Meetings.** Written notice of each meeting of the members shall be given by the Secretary at the direction of the person or persons authorized to call the meeting, by mailing a copy of such notice, postage prepaid, or by electronic delivery, not less than thirty (30) days nor more than sixty (60) days before such meeting to each member entitled to vote at such meeting, addressed to the member's address last appearing on the books of the Association, supplied by such member to the Association for the purpose of notice. Such notice shall specify the place, day, and hour of the meeting, and, in the case of a special meeting, the purpose of the meeting. *(Rev 02-23-2022 AGM)*
- 3.4 **Quorum.** The existence of a quorum at any meeting of the members shall be determined by the provision for quorums in the Declaration.

PART 4
Board of Directors

- 4.1 **Number.** The affairs of this Association shall be managed by a Board of seven (7) Directors. The Board may continue to conduct the affairs of the Association with up to two (2) vacancies on the Board. In the event three (3) Board positions become vacant, the only authorized action of the remaining members of the Board shall be to select at least one additional member of the Board. *(Revised 2/21/2024 EA)*
- 4.2 **Term of Office.** Newly elected directors shall take office at the first regular or special meeting of the Board of Directors following the election. All directors shall hold office for a two-year term, with the respective terms to be staggered so that no more than four (4) Directors are to be elected in any one year in order to provide continuity and stability in the

Association leadership. A director's time on the Board of Directors shall be limited to no more than four (4) consecutive full elected terms. No director who has completed four consecutive full terms shall be eligible to be elected or appointed to the Board until at least two years since the conclusion of that Board member's last term on the Board has elapsed. (Rev 02-15-2010 AGM)

- 4.3 Removal; Vacancy. Any directors may be removed from the Board, with or without cause, by a majority vote of the members of the Association. In the event of death, resignation or removal of a director, his successor shall be selected by the remaining members of the Board and shall serve for the unexpired term of his predecessor.
- 4.4 Compensation. No director shall receive compensation for any service he may render to the Association. However, any director may be reimbursed for his actual expenses incurred in the performance of his duties.
- 4.5 Action Taken Without a Meeting. The directors shall have the right to take any action in the absence of a meeting which they could take at a meeting by obtaining the written approval of all the directors. Any action so approved shall have the same effect as though taken at a meeting of the directors.
- 4.6 Election. Members of the Board of Directors shall be elected annually by the membership. Votes may be cast by: secret ballot, either prior to or at the annual meeting, electronic voting. A majority of the votes cast shall determine the results of the election. Write-in candidates are prohibited. (Revised AGM 02/21/2018) (Revised 2/21/2024 EA)

PART 5

Meetings of Directors

- 5.1 Regular Meetings. Regular meetings of the Board of Directors shall be held as established by the Board at such place and hour as may be fixed from time to time by resolution of the Board. Notice to owners of upcoming Board of Directors meeting will be posted in the Rumble Sheet, posted conspicuously in the lobby, posted on the outside bulletin board or by an e-mail sent to all residents. Should said meeting fall upon a legal holiday, then that meeting shall be held at the same time on the next day which is not a legal holiday. (Rev 02-23-2022 AGM)
- 5.2 Special Meetings. Special meetings of the Board of Directors shall be held when called by the President of the Association or by any two directors, after not less than forty-eight (48) hours' notice to each director and proper notice to the Association's members. Attendance at and/or

participation in a special meeting by a director constitutes a waiver of notice of the meeting. (Revised AGM 02/21/2018)

- 5.3 Quorum. A majority of the number of directors shall constitute a quorum for the transaction of business. Every act or decision done or made by a majority of the directors present at a duly held meeting at which a quorum is present shall be regarded as the act of the Board.
- 5.4 Executive Session. All Board Meetings shall be open to members of the Association, except that the Board of Directors shall have the right to convene in executive session to consider (i) personnel matters, including but not limited to employment, termination of employment and salaries, (ii) legal matters, such as consultations with legal counsel with respect to pending, threatened or contemplated litigation, and (iii) such other matters of a confidential nature, where the Board determines that the interests of the Association are best served by discussions in executive session. The proceedings of executive sessions shall be confidential. All Board resolutions shall be adopted in open session.

PART 6

Powers and Duties of the Board of Directors

- 6.1 Powers. The Board of Directors shall have power to:
- A. adopt and publish rules and regulations governing the use of the Common Areas and facilities, and the personal conduct of the members and their guests thereon, and to establish penalties for the infraction thereof;
 - B. suspend the voting rights and right to the use of the recreational facilities of a member during any period in which such member shall be in default in the payment of any assessment levied by the Association, and suspend the right to use of the recreational facilities of a member during any period in which non-monetary violations of the Declaration, Bylaws and the published Rules and Regulations of the Association remain uncured;
 - C. exercise for the Association all powers, duties and authority vested in or delegated to this Association and not reserved to the membership by other provisions of these Bylaws, the Articles of Incorporation, or the Declaration;
- 6.2 Limitations. The foregoing notwithstanding, without prior approval by a majority vote of the members at an annual meeting or special meeting of the members, the Board of Directors shall not have the power to borrow money or to make and issue notes, bonds and other negotiable instruments, mortgages, deeds of trust or take similar action nor shall the Board of Directors have the power to authorize the expenditure of \$40,000 or more on any single item which is not included in an approved

budget, unless an emergency threatening health, safety or immediate damage to property exists. (Amended 02-13-13 AGM)

- 6.3 Duties. It shall be the duty of the Board of Directors to:
- A. cause to be kept a complete record of all its acts and corporate affairs;
 - B. supervise all officers, agents and employees of this Association, and to ensure that their duties are properly performed;
 - C. to establish and enforce assessments as provided in the Declaration;
 - D. issue, or to cause an appropriate officer to issue, upon demand by any person, a certificate setting forth whether or not any assessment has been paid. A reasonable charge may be made by the Board for the issuance of these certificates. If a certificate states an assessment has been paid, such certificate shall be conclusive evidence of such payment;
 - E. procure and maintain adequate liability and hazard insurance on property owned by the Association;
 - F. cause all officers or employees having fiscal responsibilities to be bonded, as it may deem appropriate;
 - G. cause the Common Areas to be maintained;
 - H. perform or cause to be performed all other obligations of the Association described in the Declaration.

PART 7

Officers and Their Duties

- 7.1 Enumeration of Offices. The officers of this Association shall be a President, a Vice President, a Secretary, and a Treasurer, and such other officers as the Board may from time to time by resolution create. Officers shall at all times be members of the Board of Directors.
- 7.2 Election of Officers. The election of officers shall take place at the first meeting of the Board of Directors following each annual meeting of the members.
- 7.3 Term. The officers of this Association shall be elected annually by the Board and each shall hold office for one (1) year unless he or she shall sooner resign, or shall be removed, or otherwise disqualified to serve.
- 7.4 Special Appointments. The Board may elect such other officers as the affairs of the Association may require, each of whom shall hold office for such period, have such authority, and perform such duties as the Board may, from time to time, determine.
- 7.5 Resignation and Removal. Any officer may be removed from office with or without cause by the Board. Any officer may resign at any time giving written notice to the Board, the president or the secretary. Such resignation shall take effect on the date of receipt of such notice or at any

later time specified therein, and unless otherwise specified therein, the acceptance of such resignation shall not be necessary to make it effective.

- 7.6 Vacancies. A vacancy in any office may be filled by appointment by the Board. The officer appointed to such vacancy shall serve for the remainder of the term of the officer he replaces.
- 7.7 Multiple Offices. The offices of Secretary and Treasurer may be held by the same person. No person shall simultaneously hold more than one of any of the other offices except in the case of special offices created pursuant to Section 4 of this Article.
- 7.8 Duties. The duties of the officers are as follows:
- A. *President*. The President shall preside at all meetings of the Board of Directors; shall see that orders and resolutions of the Board are carried out.
 - B. *Vice President*. The Vice President shall act in the place and stead of the President in the event of his absence, inability or refusal to act, and shall exercise and discharge such other duties as may be required of him by the Board.
 - C. *Secretary*. The Secretary shall facilitate the recording of the votes and keep the minutes of all meetings and proceedings of the Board and of the members; serve notice of meetings of the Board and of the members; keep appropriate current records showing the members of the Association together with their addresses, and shall perform such other duties as required by the Board. (Revised 02/21/2018 AGM)
 - D. *Treasurer*. The Treasurer shall monitor the receipt and management of all monies of the Association and shall monitor the disbursement of funds as directed by resolution of the Board of Directors; shall ensure the keeping of proper books of account; cause an annual audit or review of Association books to be made by a public accountant at the completion of each fiscal year, however a review may not be used in consecutive years; and shall prepare an annual budget and a statement of income and expenditures to be presented to the membership at its regular annual meeting, and deliver a copy of each to the members. The annual financial report shall be made available to the members within (180) days after the close of the fiscal year. (Revised 02/15/2012 AGM)

PART 8
Committees

- 8.1 Committees. The Board of Directors shall appoint committees as deemed appropriate in carrying out its purpose. Committees shall be in accordance with Arizona state statutes where applicable. (Revised 02/21/2018).

PART 9
Books and Records

- 9.1 Books and Records. The books, records, and papers of the Association shall at all times, during reasonable business hours, be subject to inspection by any member. The Declaration, the Articles of Incorporation and the Bylaws of the Association shall be available for inspection by any member at the principal office of the Association, where copies may be purchased at a reasonable cost.

PART 10
Amendments

- 10.1 Passage of Amendments. These Bylaws may be amended, at a regular or special meeting of the members, if at least sixty percent (60%) of Members casting VALID ballots cast affirmative votes for adoption of the amended Bylaws. (02/24/1998 AGM)
- 10.2 Conflict. In the case of any conflict between the Articles of Incorporation and these Bylaws, the Articles shall control; and in the case of any conflict between the Declaration and these Bylaws, the Declaration shall control.

PART 11
Miscellaneous

- 11.1 Fiscal Year. The fiscal year of the Association shall begin on the first day of January and end on the 31st day of December of every year. (Revised 02/17/2010 AGM)

PART 12
Common Area Development Process

- 12.1 Development Process for Common Properties of Carriage Manor.
1. Any projected development of any common property will be presented to the Board of Directors (BOD) at a regular scheduled meeting.
 2. The project will be reviewed by the BOD and a determination of viability and value to the Resort in concept will be made. The BOD will vote to continue or reject with cause, (reasons) the project. A status report will be made concerning the project within 30 days.*

3. A project approved, in step 2, will be given to the Long Range Planning Committee (LRPC) and to the Resort administration. They will further investigate the project to determine if it will meet current PAD and CC&R requirements. They will also establish a preliminary budget including ongoing maintenance costs, potential financing, and set a preliminary time line for the project, or, they may recommend to the BOD that the proposed project be cancelled with cause (reason). A status report will be made within 60 days with ongoing reports every 30 days.*
4. If approval is recommended, the BOD will call a public meeting to present the project to the Resort property owners. This meeting would include all information developed to date, plus maps, drawings, more specific cost and financing plans and any other documents that support the project.
5. A ballot vote will be scheduled to vote on the continuation of the project. All votes will take place with regular annual election dates. A project shall be passed if fifty percent plus one persons of the ballots returned vote in favor of the project.
6. After an affirmative vote the sponsoring club or organization may proceed with fund raising or secure financing.
7. When at least sixty percent of the estimated cost of the project is on deposit with Carriage Manor RV Resort Association and/or a loan commitment from a creditable source, bonding, or assessment for the balance is provided, the BOD may instruct the Resort Manager to secure professional assistance, obtain permits, sign contracts and establish a timeline for the completion of the project.
8. The BOD reserves the right to waive or reduce some of the steps in this process except for the owners vote if they present cause, (reasons) to do so.

*Note. The project sponsor has the option to address the causes for denial and request reconsideration by the BOD.
(Adopted 02/20/2008)

**AMENDED AND RESTATED
DECLARATION OF COVENANTS, CONDITIONS AND RESTRICTIONS
FOR
CARRIAGE MANOR RV RESORT**

This Amended and Restated Declaration of Covenants, Conditions and Restrictions for Carriage Manor RV Resort is made and effective as of its date of recording by the Carriage Manor RV Resort Association, Inc., and Arizona nonprofit corporation.

RECITALS

- A. This Amended and Restated Declaration of Covenants, Conditions and Restrictions for Carriage Manor RV Resort (the “Declaration”) amends, restates and supersedes, in their entirety, the following documents:
1. The Declaration of Covenants, Conditions and Restrictions for Carriage Manor RV Resort recorded on June 28, 1984 as Document No. 1984-0281178¹, as re-recorded on July 16, 1984 as Document No. 1984-0307623 (the “1984 Declaration”), as amended by the First Amendment to Declaration of Covenants Conditions and Restrictions Carriage Manor RV Resort Association recorded on August 19, 1985 as Document No. 1985-0391131, and as amended by the Second Amendment to Declaration of Covenants Conditions and Restrictions Carriage Manor RV Resort Association recorded on February 27, 1986 as Document No. 1986-0095711;
 2. The Restated Declaration of Covenants, Conditions and Restrictions for Carriage Manor RV Resort recorded on December 16, 1987 as Document No. 1987-0743929, as corrected by the Affidavit of Scrivener’s Error recorded on March 31, 1988 as Document No. 1988-0150985, as amended by the First Amendment to Restated Declaration of Covenants, Conditions and Restrictions for Carriage Manor RV Resort recorded on March 8, 1989 as Document No. 1989-0105515, and as amended by the Second Amendment to Restated Declaration of Covenants, Conditions and Restrictions for Carriage Manor RV Resort recorded on April 5, 1990 as Document No. 1990-0150818;
 3. The Restated Declaration of Covenants, Conditions and Restrictions for Carriage Manor RV Resort recorded on April 13, 1993 as Document No. 1993-0221225;
 4. The Restated Declaration of Covenants, Conditions and Restrictions for Carriage Manor RV Resort recorded on June 5, 1997 as Document No. 1997-0381941, as amended by the First Amendment to Amended and Restated Declaration of Covenants, Conditions and Restrictions for Carriage Manor RV Resort recorded on April 20, 1999 as Document No. 1999-0371185;

¹ All documents listed in Recital A are recorded in the official records of the Maricopa County Recorder, State of Arizona, unless otherwise noted.

5. The Amended and Restated Declaration of Covenants, Conditions and Restrictions for Carriage Manor RV Resort recorded on April 23, 2013 as Document No. 2013-0367812;
6. The Governing Documents for Carriage Manor RV Resort recorded on July 19, 2019 as Document No. 2019-0549451;
7. The Amended and Restated Declaration of Covenants, Conditions and Restrictions for Carriage Manor RV Resort recorded May 29, 2020 as Document No. 2020-0464522;
8. The Amended and Restated Declaration of Covenants, Conditions and Restrictions for Carriage Manor RV Resort recorded in October 26, 2022 as Document No. 2022-0801748 (the documents listed in Section A(1) through (8), inclusive, are collectively referred to as the "Original Declaration").

B. Section 14.6 of the Original Declaration permits the amendment of the Original Declaration by a vote of sixty percent (60%) of the Owners of the Property.

C. By a duly held vote of the Carriage Manor RV Resort Association, Inc., in excess of sixty percent (60%) of the Owners of the Property approved this Amended and Restated Declaration of Covenants, Conditions and Restrictions for Carriage Manor RV Resort.

D. The Owners desire that all of the Property subject hereto be held, conveyed, hypothecated, encumbered, leased, occupied, built upon and otherwise used, improved or transferred in whole or in part, subject to this Declaration, as amended or modified from time to time.

NOW THEREFORE, the Original Declaration is hereby amended, restated, superseded and revoked in its entirety, and the provisions of this Amended and Restated Declaration of Covenants, Conditions and Restrictions for Carriage Manor RV Resort are hereby imposed upon the Property.

PART 1 **Definitions**

- 1.1 Articles. Articles shall mean the Articles of Incorporation of the Association which have been filed in the Office of the Corporation Commission of the State of Arizona, as said Articles may be amended from time to time.
- 1.2 Assessments. Assessments shall include the following:
 - A. *Regular Annual Assessment*. Regular Annual Assessment shall mean the Regular Annual Assessment paid on a monthly, quarterly, or annual basis by each Owner of the Association for Common Expenses.
 - B. *Special Assessment*. Special Assessment shall mean a charge against

and directly attributable to a particular Owner and such Owner's Lot, together with attorneys' fees and other charges payable by such Owner pursuant to this Declaration, plus any and all interest thereon as provided for in this Declaration.

C. Supplementary Assessment. Supplementary Assessment shall mean a pro rata charge against each Owner and such Owner's Lot for the installation or construction of capital improvements on the Common Areas.

- 1.3 Association. Association shall mean and refer to Carriage Manor RV Resort Association, Inc., an Arizona non-profit corporation, its successors and assigns.
- 1.4 Association Rules. Association Rules shall mean the rules and regulations adopted and promulgated from time to time by the Association.
- 1.5 Board. Board shall mean the Board of Directors of the Association.
- 1.6 Bylaws. Bylaws shall mean the Bylaws of the Association as amended from time to time.
- 1.7 Commercial Truck. Commercial Truck is one that is used in Trade, Crafts, (i.e. electrical, plumbing, carpentry, service work and etc.) and Business.
- 1.8 Common Areas. Common Areas shall mean all real property, owned by the Association, including all buildings, structures, improvements and fixtures thereon, and shown on the Subdivision Plat.
- 1.9 Common Expenses. Common Expenses shall mean the expenses incurred by the Association in the good faith judgment of the Board for the management, preservation, protection, repair or construction of the Common Areas or in furtherance of the purposes of the Association or in the discharge of any obligation imposed on the Association by this Declaration.
- 1.10 Improvement. Improvement shall mean all buildings, structures, improvements, roads, roadways, parking areas, lighting fixtures, fences, walls, hedges, plantings, planted trees and shrubs, recreational or sporting areas, and all other structures or landscaping of every type and kind now or hereafter located on the Property.
- 1.11 Lot. Lot shall mean and refer to each separate parcel of real property shown and designated as a Lot from time to time upon the Subdivision Map. The term "Lot" shall exclude Common Areas.
- 1.12 Member. Member of the Association shall mean any person, corporation,

partnership, joint venture or other entity who is an Owner.

- 1.13 Owner. Owner shall mean and refer to the record owner, whether one or more persons or entities, of equitable or beneficial title (or legal title if same has merged) of any Lot. "Owner" shall not include the purchaser of a lot under an unrecorded executory contract for the sale of property or persons or entities who hold an interest in a Lot merely as security for the performance of an obligation. Except as stated otherwise herein, "Owner" shall not include a lessee or tenant of a Lot. For the purposes of Part 3 only, unless the context otherwise requires, "Owner" shall also include the family, guests, visitors, invitees, licensees, and lessees of any Owner, together with every other person with a possessory interest in a Lot.
- 1.14 Park Model. Park Model shall mean a vehicle of not less than 320 nor more than 400 square feet of living space, with plumbing, heating, or electrical systems that will not operate without being connected to outside utilities.
- 1.15 Property. Property shall mean the real property subject to this Declaration, which is described on the attached Exhibit A.
- 1.16 Purchaser. Purchaser shall mean any person or other entity who becomes an Owner of any Lot by conveyance, gift, foreclosure, operation of law, devise, descent or any other transfer of title to such Lot.
- 1.17 Recreational Vehicles. Recreational Vehicle shall mean a vehicle with or without its own mode of power designed to provide temporary living quarters for recreational, camping or travel use, but excluding any vehicle with plumbing, heating, or electrical systems that will not operate without being connected to outside utilities. A vehicle otherwise qualifying as a recreational vehicle is not disqualified solely because said vehicle is in fact temporarily connected to one or more outside utility systems.
- 1.18 *(Removed 2/21/2024 EA)*
- 1.19 Single Family. Single Family shall mean a group of not more than two persons who maintain a common household, unless otherwise approved by the Association.
- 1.20 Subdivision Map or Subdivision Plat. Subdivision Map or Subdivision Plat shall mean the recorded plat of Carriage Manor recorded in the office of the Maricopa County Recorder, at Book 269 of Maps, Page 20, and the plat of Carriage Manor R.V. Resort II, as recorded in Book 282 of Maps, Page 27, as said plats may be amended or replaced from time to time together with the recorded plat of any additional property hereafter subjected to the Declaration.
- 1.21 Tract. Tract shall mean any real property designated as a Tract on the Subdivision Map.

- 1.22 Visible from Neighboring Property. Visible from Neighboring property with respect to any given object, that such object is or would be visible to a person six feet tall, standing on any part of the Neighboring property at an elevation equal to the elevation of the base of the object being viewed.
- 1.23 Manufactured Home. A Manufactured Home means a structure built in accordance with the National Manufactured Home Construction and Safety Standards Act of 1974 and Title VI of the Housing and Community Development Act of 1974 (P.L. 93-383, as amended by P.L. 95-128, 95-557, 96-153 and 96-339).
- 1.24 Factory Built Building. A Factory-Built Building means a residential or nonresidential building including a dwelling unit or habitable room thereof which is either wholly or in substantial part manufactured at an off-site location to be assembled on-site, except that it does not include a manufactured home, recreational vehicle or mobile home as defined in Arizona Revised Statutes 41-4001.
- 1.25 Mobile Home. A Mobile Home means a structure built prior to June 15, 1976, on a permanent chassis, capable of being transported in one or more sections and designed to be used with or without a permanent foundation as a dwelling when connected to on-site utilities except Recreational Vehicles and Factory-Built Buildings.

Part 2

Common Areas

- 2.1 Owner's Right of Enjoyment. Every Owner shall have a right and easement of enjoyment in and to the Common Areas for the purposes of access, ingress to and egress from, use, occupancy and enjoyment of the Lot owned by such Lot Owner. Subject to the Rules and Regulations adopted from time to time by the Association, an Owner's use of the Common Areas shall include members of the Owner's family, guests, invitees, and visitors (collectively, "Guests").
- 2.2 Transfer of Use of Common Areas. Except as otherwise provided herein, an Owner may transfer his right of enjoyment to the Common Areas to the Owner's tenants and lessees (collectively, the "Lessee"). If the Owner has transferred the Owner's right of enjoyment to the Common Areas to the Owner's Lessee, the Owner shall not have the right of enjoyment of the Common Areas unless otherwise provided by the Association. The Association may also reasonably limit the use of Common Areas by Owners of fractional interests in a Lot and holders of interests under other shared ownership arrangements. Guests and Lessees shall be subject to the terms and provisions of this Declaration and the Articles, Bylaws, and Association Rules.

- 2.3 Conveyance of Common Areas. An Owner's interest in the Common Areas shall not be conveyed, transferred, alienated or encumbered separate from the Owner's Lot. Such interest shall be deemed to be conveyed, transferred, alienated or encumbered upon the sale of a Lot, whether or not the instrument of conveyance, transfer, alienation or encumbrance refers to the Common Areas. Reference in a deed or other instrument to a specific Lot alone shall be sufficient to legally describe all rights, interests, and easements appurtenant to said Lot.
- 2.4 Partition of Common Areas. The Common Areas shall remain undivided and no action for partition or division of any part thereof shall be permitted.
- 2.5 Abandonment or Failure to Use Common Areas. No Owner may exempt himself from liability for Assessments with respect to the Common Areas or any other obligation under the Declaration by waiving or failing to exercise the right to use the Common Areas or by abandonment of his Lot or otherwise.

PART 3 **Use Restrictions**

- 3.1 Use Limited to Recreational Vehicles, Park Models and Manufactured Homes. All Lots shall be solely for the parking and occupancy of Recreational Vehicles, Park Models or Manufactured Homes. It is the declared intention of the Association to exclude Mobile Homes and Dwelling Houses from the Property and to create and maintain the Property as a resort solely for the use of owners and operators of Recreational Vehicles, Park Models, or Manufactured Homes. (Revised 02/15/2012 AGM)
- 3.2 Commercial Uses Prohibited. No occupation, business, profession, trade or other commercial or business activity shall be conducted on any portion of the Property except as may be specifically approved from time to time by the Association. The mere leasing of a Lot for residential purposes from time to time does not constitute a commercial or business use of Lot.
- 3.3 Parking on Lots. No more than one (1) Recreational Vehicle or Park Model and up to two (2) pick-up trucks or passenger cars (including passenger vans seating less than nine (9) passengers) shall be parked or maintained on any Lot. No more than one (1) motorcycle or golf cart. In place of two (2) passenger vehicles: i.e., one (1) passenger vehicle plus two (2) golf carts OR two (2) motorcycles; OR one (1) golf cart and one (1) motorcycle shall be parked or maintained on any Lot. Furthermore, maintaining more than three (3) vehicles on any Lot shall be prohibited. (Amended 02/19/14 AGM)

- 3.4 Parking on Common Areas. No Recreational Vehicle shall be parked or located on the Common Areas or any public roads or streets within the Property. No cars, motorcycles or other motor vehicles shall be parked or located on the Common Areas or on any roads or streets within the Property except in parking spaces or parking areas designated under the Association Rules. No non-operable car, pick-up truck, or passenger van shall be parked or stored on the Common Areas for more than five (5) days. No automotive or mechanical repair work shall be performed on the Common Areas. No Commercial Truck shall be parked or maintained on the Common Areas, except for temporary daily parking by Commercial Trucks involved in rendering service to a Lot, Recreational Vehicle, or the Common Areas. The Association shall have the right to have vehicles violating this restriction towed at the vehicle owner's expense. (Revised 02/24/1998 AGM)
- 3.5 Additional Parking Restrictions. No non-operable car, pick-up truck, or passenger van shall be parked or stored on any Lot for more than five (5) days. No automotive or mechanical repair work shall be performed on any Lot. No Commercial Truck shall be parked or maintained on any Lot, except for temporary daily parking by Commercial Trucks involved in rendering service to a Lot. Owner and/or Renter shall be allowed to park one towing vehicle that is to move their recreational vehicle safely. The towing vehicle shall use the designated parking space as called out in the Design Guidelines and the Rules and Regulations of the Association on the owned or rented Lot. (Revised 02/24/1998 AGM)
- 3.6 Vehicle Appearance. All Recreational Vehicles, Park Models and other vehicles on the Property shall be maintained to present a neat and attractive appearance.
- 3.7 Antennas. No antenna or other device for the transmission or reception of television or radio signals or any other form of electromagnetic radiation shall be erected, used or maintained outdoors on any portion of the Property whether attached to a building, structure, Recreational Vehicle, a Park Model or otherwise, unless approved by the Association. The preceding sentence shall not prohibit a Recreational Vehicle, a Park Model or other vehicle from having a single permanently mounted standard AM/FM radio antenna not exceeding four (4) feet in length and of the type customarily furnished with passenger automobiles together with no more than two (2) "citizen's band radio" or "ham radio" antennas of like size and appearance. Recreational Vehicles and Park Models may also have a single, permanent, roof-mounted television antenna or television reception satellite dish not exceeding sixty (60) inches in overall horizontal dimension. No portion of any antenna or dish shall extend past the edge of the roof of the Recreational Vehicle, Park Model or other vehicle, and the tallest part of any antenna or dish (including its mount) shall be no more than forty-eight (48) inches above the highest point of the roof of the Recreational Vehicle, Park Model or other vehicle. (See

Exhibit F, Criteria for Amateur Radio (Ham Radio) Installations.)

- 3.8 Utility Service. Except for the temporary hookup between a permanent utility outlet and a Recreational Vehicle on the same Lot, no lines, wires, or other devices for the communication or transmission of electric current or power, including telephone, television and radio signals, shall be erected, placed or maintained anywhere in or upon the Property unless the same shall be contained in conduits or cables installed and maintained underground or concealed in, under or on buildings or other structures. All temporary utility hookups between Recreational Vehicles and permanent utility outlets shall be installed and maintained in a manner to minimize visibility and present an attractive appearance and in accordance with applicable provisions of the Association Rules. No provision hereof shall be deemed to forbid the erection of temporary power or telephone installations incident to the construction of permitted buildings or structures.
- 3.9 Lot Maintenance. No Recreational Vehicle, Park Model, Improvement, or Lot shall be permitted to fall into disrepair or to become unsafe, unsanitary or unsightly. All Recreational Vehicles, Park Models, Lots, and Improvements shall at all times be kept in good condition and repair and adequately painted or otherwise finished. The Association shall have the right, after thirty (30) days' notice (or without notice in the event of an emergency), to cause to be repaired or otherwise maintained the exterior of any Improvement, Recreational Vehicle, Park Model, or Lot which the Association, determines in its sole discretion is in violation of this provision. No notice shall be required in order for the Association to cut weeds determined by the Association to be unsightly or unsafe. All costs and expenses so incurred by the Association shall be borne by the Owner, and shall be paid to the Association on demand. Any sum not paid by an Owner shall be deemed and treated as a Special Assessment and, if unpaid, may be collected in a like manner as delinquent Assessments.
- 3.10 Trash Containers; Collections; Incinerators. No garbage, junk, rubbish or trash shall be placed or kept on any portion of the Property, except in covered containers of the type, size, style and location approved from time to time by the Association or authorized by the Association Rules. The Association shall have the right, in its sole discretion, to require all Owners to subscribe to a trash service. All rubbish, trash, junk and garbage shall be removed from the Lots and shall not be allowed to accumulate thereon. No incinerators shall be used, kept or maintained on any Lot.
- 3.11 Overhangs. No tree, shrub, planting, structure or improvement of any kind on any Lot shall be allowed to overhang or otherwise encroach upon any portion of the Common Areas without the prior written approval of the Association.

- 3.12 Machinery and Equipment. No machinery or equipment of any kind shall be placed, operated or maintained on any portion of the Property except such machinery or equipment as is usual and customary in connection with the use and ordinary and routine maintenance and enjoyment of Recreational Vehicles, Park Models, or Improvements. The preceding sentence does not prohibit machinery and equipment the Association may require for the operation and maintenance of the Common Areas.
- 3.13 Restriction on Further Subdivision. No Lot shall be further subdivided, separated or partitioned by any Owner, and no portion less than all of any such Lot shall be conveyed or transferred by any Owner, without the approval of Members representing at least sixty percent (60%) of the total votes in the Association. No Lot may be converted to condominium, cooperative or other similar type of ownership.
- 3.14 Signs.
- A. Except as otherwise provided in this Section 3.14, no signs Visible from Neighboring Property shall be placed or kept on any Lot without the Association's prior written approval.
 - B. Owner's may place address signs in number, size, construction, appearance, and location complying with Association Rules identifying individual Lots. Within twenty (20) days of placing a Recreational Vehicle on a Lot, the Owner shall also place on or about such Lot a sign provided by the Association identifying the Lot number of such Lot (or other address assigned to such Lot by the Association). Such sign shall be visible to traffic passing in front of the Lot and shall conform to Association Rules regulating such signs.
 - C. Owner's may place such signs as are authorized by Arizona law, at A.R.S. & 33-1808, as the same may be amended from time to time, and in accordance local laws and Association's Rules. *(Revised 2/21/2024 EA)*
- 3.15 Future Utility Installations. To the extent reasonable as determined in the sole discretion of the Association, utilities installed subsequent to the initial development of the Property shall be constructed and maintained in such a manner as to minimize the inconvenience to, disruption of, or alteration of appearance of the Common Areas.
- 3.16 Offensive Activities and Nuisances. No noxious or offensive activity shall be carried on upon any part of the Property, including the Common Area and any Lot, nor shall anything be done thereon which may be, or may become, an annoyance or nuisance to the neighborhood, or to the Property as a whole, or which shall in any way interfere with the quiet enjoyment by each Owner of that Owner's Lot, or which shall in any way increase the rate of any insurance respecting the Property or any Lot. Each Lot, Park Model, and Recreational Vehicle shall be kept in a sanitary condition, free of offensive odors and insect infestation. No rubbish or debris of any kind shall be placed or permitted to accumulate upon the

Property and no odors or insect infestation shall be permitted to arise or escape therefrom so as to render any portion of the Property unsanitary, unsightly, offensive or detrimental to any other portion of the Property.

- 3.17 Noise. No unauthorized exterior speakers, horns, whistles, bells, or other sound devices except security devices used exclusively for security purposes, shall be located, used or placed on the Property. Devices such as cutouts on exhaust systems, noisy mufflers, etc., are prohibited within the Property.
- 3.18 Laundry Facilities. Outside clotheslines or other outside facilities for drying or airing clothes shall not be erected, placed or maintained on any portion of the Property. Without the prior written approval of the Association, no washing machine or dryer shall be kept or maintained on any Lot, except within a Recreational Vehicle, Park Model, patio enclosure (Arizona Room), or storage building.
- 3.19 Mineral Exploration. No portion of the Property shall be used in any manner to explore for or to remove any water, oil or other hydrocarbons, minerals of any kind, gravel, earth or any earth substances of any kind.
- 3.20 Maintenance of Drainage Facilities. No Owner shall obstruct, divert, alter or interfere in any way with the drainage of groundwater upon, across or over any portion of the Property, including Lots. The Association shall maintain the drainage-ways and channels located on individual Lots. The Association shall have the right upon reasonable notice (or without notice in an emergency), to go upon such individual Lot to repair or otherwise maintain drainage ways or channels.
- 3.21 Lighting. Flood lighting, security lighting, and other high intensity lighting is authorized only if approved by the Association or expressly authorized by the Association Rules. All such lighting must be shielded and directed so as not to beam into the roads or the Lot of any neighbor, or in any way create a nuisance or be in violation of a neighbor's privacy.
- 3.22 Temporary Structures. No structure of a temporary character, (tent, shack, garage, barn or other outbuilding) shall be used on the property at any time, except as may be authorized by the Association. (Revised 02/20/2019 AGM)
- 3.23 Animals. No animals, livestock or poultry of any kind shall be raised, bred or kept on any Lot, except that a total of not more than two (2) household pets may, subject to compliance with Association Rules, be kept on any Lot. Pets may not be kept, bred or maintained for any commercial purpose. All pets not confined to a cage or a vehicle, or tethered on a Lot so as to be unable to reach any boundary of the Lot, shall be kept on a leash held by a human being. The leash must be of such length as required by the Association Rules. No pet shall be allowed to relieve itself on the Common Areas or

another Owner's Lot. It shall be the collective responsibility of the persons in possession of, having charge of, or owning any pet to remove immediately any droppings from the pet. The Association is expressly authorized to promulgate rules and regulations further restricting the keeping of pets on the Property. By way of example but not limitation, the Association may adopt regulations requiring the registration of pets, establishing fees for pet registration, and otherwise restricting the keeping of pets on the Property. The Association is expressly authorized to capture pets roaming at large, immediately remove noisy pets from the Property, and assess fines not exceeding per Lot the lesser of twenty-five dollars (\$25) per day or as provided for under section 15.2 of the Rules & Regulations for failure to comply with the Declaration's or the Association Rules provisions regarding pets. All rules adopted by the Association pertaining to pets shall be deemed to be reasonable and enforceable unless disapproved by a vote of ninety percent (90%) of the Members. The intent of this paragraph is to preserve the peace, quiet and cleanliness of the Property. (Revised 02/25/2026 AGM)

- 3.24 Air Conditioning and Other Systems. No air conditioning or heating units, hot water heaters, compressors, solar panels, solar collectors or similar devices shall be erected, constructed, placed or installed or permitted to remain on the rooftop of any Park Model or Recreational Vehicle (unless factory installed) or any structure, unless the same have been approved in writing by the Association. The Association is expressly authorized to promulgate rules and regulations governing the installation or restrictions of all or any such devices.
- 3.25 Rugs. No garments, rugs, laundry or other similar objects shall be hung from the windows or from any facade of a Recreational Vehicle, Park Model, or patio enclosure (Arizona Room).
- 3.26 Reflective Materials. No reflective materials, including but not limited to, aluminum foil, reflective screens or glass, mirrors or similar type on the outside or inside of any windows of a Recreational Vehicle, Park Model, or structure unless expressly authorized by the Association Rules. Enclosures, shades, screens or other items affecting the exterior appearance of any patio shall not be permitted without the express prior written consent of the Association.
- 3.27 Improvements. All Improvements shall comply with the setback, height and other requirements indicated on the Subdivision Plat. In addition, no Improvement shall be constructed, located or maintained on any Lot within seven (7) feet from the front boundary line, five (5) feet from the side and five (5) feet from the rear boundary lines, except as may be authorized in writing by the Association. In addition, setback laws of the City of Mesa shall be observed.
- 3.28 Propane Tanks. Only propane tanks utilized in connection with barbecue grills, outdoor propane heaters and Recreational Vehicles shall be

permitted on any Lot. Such tanks must be in compliance with all applicable codes and laws and the Association Rules. (Revised 02/17/2016)

- 3.29 Age Restriction. Except as hereinafter set forth or in the Policies and Procedures regarding Housing for Older Persons described below, at least one occupant of each Lot must be 55 years of age or older, and no occupant under the age of 40 years may reside upon any Lot. It is the intent and purpose of this Section 3.29 to qualify Carriage Manor RV Resort for exemption from the "familial status" provisions of the Fair Housing Act (42 U.S.C. 3600-3620) (the "Act") pursuant to the "Housing for Older Persons" exemption set forth therein, specifically requiring that at least one person 55 years of age or older occupy each Lot. In order to implement this Section 3.29 and to satisfy the requirements for exemption as set forth in the Act and the Regulations thereunder promulgated by the Department of Housing and Urban Development (the "Regulations"), the Association shall adopt and maintain in force at all times, Policies and Procedures regarding Housing for Older Persons, whereby the Association shall provide for any and all matters determined to be necessary by the Association in order to fulfill the requirements of the "Housing for Older Persons" exemption as set forth in the Act and the Regulations, and which Policies and Procedures shall govern the ages of all occupants of Lots within Carriage Manor as set forth therein.
- 3.30 Solicitation. No door-to-door sales or other solicitation of funds shall be permitted on the Property unless expressly permitted by the Association Rules.
- 3.31 Age of Recreational Vehicles and Park Models. No Recreational Vehicle or Park Model more than ten (10) years old as measured from the earlier of the Recreational Vehicle's or Park Model's model year or actual date of manufacture shall be permitted to be brought onto any Lot except that, upon the express determination by the Association that a Recreational Vehicle is and will remain in sufficiently good condition to be safe and to present a neat, attractive and new appearance, the Association in its sole and absolute discretion may permit Recreational Vehicles more than ten (10) years old.
- 3.32 Required Landscaping. Within forty-five (45) days of the purchase of a Lot, said Lot shall be landscaped in accordance with plans and specifications approved by the Association. All private landscaping or potted plants on any Lot shall be properly maintained, watered, and trimmed by the Owner of the Lot.
- 3.33 Utility Facility Maintenance. All fixtures and equipment within a Lot, commencing at a point where utility lines, pipes, wires, ducts, conduits or systems enter the vertical boundary of the Lot, shall be maintained and kept in good repair by the Owner of the Lot.

- 3.34 Promulgation of Rules. The Association is hereby expressly authorized to establish reasonable rules and regulations for the purpose of implementing, enforcing and administering the provisions of this Article 3.
- 3.35 Grand-fathered Conditions. Any placement of Recreational Vehicles or Park Models, or any constructed Arizona room, deck, awning, built-in shed, masonry or chain link fence in existence on any Lot on November 17, 1992, shall not be in violation of this Declaration or any rules, regulations or guidelines adopted pursuant to this Declaration, except for such conditions for which the Owner of a Lot has received an Association "Written Notice of Violation. Any replacement of the above items shall be required to conform to this Declaration and any rules, regulations and guidelines in effect at the time of such replacement. This paragraph does not affect the requirement that all Owners comply with all city, county, state or federal laws or codes.
- 3.36 Excess Lots. No Owner may own, either directly or indirectly as a shareholder, beneficiary of a trust, member of a limited liability company, partner in a partnership, or holder of any similar interest in an entity which is the legal owner of a Lot, more than two (2) Lots at one time. Owners who own more than two (2) Lots on the date of recording of October 26, 2022 ("Excess Lots") shall be permitted to retain such Excess Lots, provided that upon the sale of any Lots in excess of two (2), no replacement or additional Lots may be acquired. **(Revised 02/23/2022 AGM)**
- 3.37 Transfer of Lots. At the time of transfer of ownership, Lots will be reviewed to verify compliance with Carriage Manor Architectural Design Guidelines. The Lot review will be conducted jointly with Administration and a member of the Architectural Review Committee. The seller of the Lot will be obligated to correct any violation(s) of design guidelines prior to transfer of ownership, or the buyer will accept the Lot with the responsibility to correct items within 60 days of taking possession of the Lot. **(Adopted 02/21/2018 AGM)**
- 3.38 Leasing Limitations.
A. No Owner may lease or rent his, her, its Lot for a term of less than twenty-eight (28) consecutive days. All Owners who lease their Lots must ensure their tenants meet the minimum age requirement as set forth in Section 3.29 of this Declaration. All Owners who lease their Lots must also ensure that their tenants abide by Carriage Manor's Governing Documents at all times. This goes into effect March 1, 2022 and is only for new lease agreements after that date. **(Revised 02/23/2022 AGM)**
B. Owners who obtained title to their Lot(s) after March 1, 2022, are prohibited from renting their Lot(s) during the months of June, July and August. **(Adopted 02/23/2022 AGM) (Revised 2/21/2024 EA)**

PART 4

Easements

- 4.1 Right of Inspection. During reasonable hours, the Association and its agents shall have the right to enter upon and inspect any portion of the Property, including any Lot (except for the interior of any Recreational Vehicle, Park Model, or patio enclosure (Arizona Room) for the purposes of ascertaining whether the provisions of this Declaration or the Association Rules have been or are being violated and exercising the Association's rights hereunder.
- 4.2 Lot Setbacks. Each Lot shall be subject to a setback area across the front seven (7) feet, on both sides five (5) feet, and the rear five (5) feet of each Lot. No permanent structures, or Improvements (other than landscaping), vehicles (other than golf carts and motorcycles), Park Models Manufactured Homes or Recreational Vehicles shall be located within such setback area. However, moveable steps, AC units and vinyl storage shed/chests are allowed in the rear setback area. The foregoing notwithstanding, Recreational Vehicles over thirty-eight (38) feet, but not more than forty (40) feet in length, which may be located on a Lot for less than 300 days in any calendar year, shall be allowed to infringe upon the seven (7) foot setback by up to two (2) feet. (Revised 02/20/2019 AGM)
- 4.3 Utility Easements. There is hereby created, in addition to such other utility or other easements as may now or hereafter exist, an easement upon, across, over and under the front seven (7) feet, on both sides three (3) feet, and the rear five (5) feet of each Lot, for ingress, egress, installation, replacing, repairing and maintaining all utility and service lines and systems, including, but not limited to, water, sewers, gas, telephones, electricity, television cable or communication lines and systems, etc. By virtue of this easement, it shall be expressly permissible for a utility or service company to install and maintain facilities and equipment on the Property and to affix and maintain wires, circuits and conduits on, in and under the Property. Notwithstanding anything to the contrary contained in this paragraph, no sewers, electrical lines, water lines, or other utilities or service lines may be installed or relocated on said Property except as approved by the Association.
- 4.4 Drainage Easement. There is hereby created, in favor of the Association, a blanket easement for drainage of groundwater on, over and across the Property.
- 4.5 Easement for Encroachments. There are hereby created blanket easements across each Lot for encroachments, overhangs, and overlaps of plants, landscaping, buildings, structures and improvements located from time to time on the Common Areas.
- 4.6 Entry to Install and Maintain Landscaping. The Association shall have the right, at any time, to plant, replace, maintain and cultivate shrubs, trees, grass and plantings on any property within the Property other than

on a Lot, and on such easements over an Owner's Lot as may have been granted to the Association regardless of whether any Owner or the Association is responsible hereunder for maintenance of such areas. No Owner shall remove, alter, injure or interfere in any way with any shrubs, trees, grass or plantings placed upon any such property by the Association without the written consent of the Association having first been obtained. The Association shall have the right to enter upon any property at any reasonable time for the purpose of planting, replacing, maintaining or cultivating such shrubs, trees, grass or plantings.

PART 5

Application of Declaration to Guests and Others

- 5.1 **Guests Subject to Declaration.** The provisions of this Declaration, the Bylaws and the Association Rules are binding upon all Owners and also upon all other persons possessing, occupying or using the Property or any portion thereof and the Association may enforce this Declaration, the Bylaws and the Association Rules against all such other persons. Notwithstanding the foregoing, Owners are ultimately responsible for ensuring that those persons whom they have authorized to possess, occupy or use the Property or their Lot, as well as any Guests, comply with this Declaration, the Bylaws and the Association Rules and may also be held responsible for any such person's violation.
- 5.2 **Declaration Incorporated in Lease.** The Declaration, Bylaws and Association Rules, shall be deemed incorporated within and made a part of every lease, rental, sublease or other agreement or understanding (collectively the "Lease") whereby an Owner or other person allows possession, use or occupy any portion of the Property by another.
- 5.3 **Notice to Lessee.** No Owner shall allow that Owner's Lot to be occupied by persons other than the Owner and the Owner's immediate family, without first notifying the proposed lessee, tenant or occupant (collectively, the "Lessee"), in writing, that use of the premises is subject to this Declaration, the Bylaws, and the Association Rules. The Owner shall secure from the Lessee a written agreement to abide by all of the covenants, conditions and restrictions contained in this Declaration, the Bylaws, and the Association Rules, and the Owner shall furnish the Association an executed copy of such written agreement. The Lease shall also expressly condition the Lessee's right to occupy the Lot upon the observance by Lessee and the Lessee's Guests of the provisions of this Declaration and the Association .
- 5.4 **Action by Association.** Any breach of the Declaration by Lessee or any guests of Lessee shall entitle the Association to initiate all available action in the name of the Association or in the name of the Owner, or both, to enforce this Declaration, the Bylaws, the Association Rules, the Lease, including the termination of the Lease, and to be entitled to be

awarded exclusive possession of the Lot with respect to the Lessee.

- 5.5 Cost of Action by Association. In the event the Association institutes any legal action or takes other action to enforce the Declaration or Association Rules, the costs and expenses of said action, including attorneys' fees, costs and expenses, shall be paid by the Owner to the Association and shall be secured by the lien against the Owner's Lot, as provided herein for Assessments.

PART 6

Association Organization and Membership

- 6.1 Formation and Organization. Carriage Manor RV Resort Association, Inc. has been formed as a Non-Profit Arizona Corporation and shall serve as the governing body for all of the Lot Owners for the maintenance, repair, replacement, administration and operation of the Common Areas as provided in this Declaration. A Board of Directors of not less than three (3) nor more than seven (7) members, and such officers as may be appointed pursuant to the Articles and the Bylaws shall conduct the affairs of the Association in accordance with the Declaration, Articles and Bylaws. The Directors of the Association must be Members of the Association *(Revised 2/21/2024 EA)*
- 6.2 Membership. Upon becoming the Owner of a Lot an Owner shall automatically become a Member of the Association and said Owner shall be and remain a Member of the Association until such time as his ownership of a Lot ceases, at which time membership in the Association shall cease automatically. Only Owners shall be Members. Ownership of a Lot shall be the sole qualification and criterion for membership. Persons or entities who hold an interest merely as security for the performance of an obligation are not entitled to membership.
- 6.3 Transfer of Membership. A membership in the Association shall not be sold, assigned, transferred, pledged, hypothecated or alienated in any way except upon the transfer, pledge, hypothecation or alienation of such Lot, and then only to such purchaser, or encumbrancer, or by intestate succession, testamentary disposition, foreclosure of mortgage or sale under a deed of trust, or other legal process. An encumbrance or lien upon a Lot shall similarly be deemed an encumbrance or lien upon the membership appurtenant to that Lot. Any attempt to make a prohibited transfer is void and will not be reflected upon the books and records of the Association.
- 6.4 Membership Records and Voting. Each record Owner of a Lot shall be entitled to one membership in the Association. The record Owner or Owners of a Lot shall be entitled to one (1) vote for each Lot owned. The vote must be cast as a unit, and fractional votes shall not be allowed. In the event more than one vote is cast for a particular Lot, none of the votes shall be

counted and all of those votes shall be deemed void. Membership shall be evidenced by an official list of Members kept by the Secretary of the Association.

- 6.5 Meetings. Regular meetings of the Members of the Association shall be held with the frequency, and at the time and place specified in the Bylaws but no less often than once each calendar year. Special Meetings may be called as provided in the Bylaws.
- 6.6 Quorum. At all meetings of the Members of the Association, the presence of Members both in person and by absentee ballot entitled to cast at least fifty percent (50%) of the total votes in the Association shall constitute a quorum. If the required quorum is not present at any meeting of the Members, another meeting may be called pursuant to the Bylaws, and, if the required notice of that meeting is sent within thirty (30) days of the meeting at which a quorum was not present, the required quorum at the subsequent meeting shall be one-half (1/2) of the required quorum at the preceding meeting. At no time shall quorum be less than twenty-five percent (25%) of all votes.
- 6.7 Indemnification. The Association shall indemnify any and all of its directors, officers, committee members, former directors, former officers, and former committee members, against all expense incurred by them and each of them, including but not limited to legal fees, judgments and penalties which may be incurred, rendered or levied in any legal action brought against any of them for or on account of any action or omission alleged to have been committed while acting within the scope of his or her duties as director or officer of the Association. Whenever any director, officer, former director or former officer shall report to the President of the Association that he has incurred or may incur expenses, including but not limited to legal fees, judgments and penalties in a legal action brought or about to be brought against him for or on account of any action or omission alleged to have been committed by him while acting within the scope of his or her duties as a director or officer of the Association, the Board of Directors shall, at its next regular or at a special meeting held within a reasonable time thereafter, determine in good faith whether, in regard to the matter involved in the action or contemplated action, such person acted in good faith, such person reasonably believed, in the case of conduct in an official capacity, that the conduct was in the Association's best interests or, in all other cases, that the conduct was at least not opposed to the Association's best interests and, in the case of criminal proceedings, that such person had no reasonable cause to believe the conduct was unlawful. If a majority of the Board of Directors determines in good faith that such person reasonably believed, in the case of conduct in an official capacity, that the conduct was in the Association's best interests or, in all other cases, that the conduct was at least not opposed to the Association's best interests and, in the case of criminal proceedings, that such person had no reasonable cause to believe the conduct was

unlawful, indemnification shall be mandatory and shall be automatically extended as specified herein, and as provided for A.R.S. § 10-3851 provided, however, that no such indemnification shall be available with respect to liabilities under the Securities Act of 1933, and provided further, that the Association shall have the right to refuse indemnification in any instance in which the person to whom indemnification would otherwise have been applicable shall have unreasonably refused to permit the Association, at its own expense and through counsel of its own choosing, to defend such person in the action.

PART 7

Powers of the Association

- 7.1 Powers and Authority of the Association. The Association shall have all of the powers of an Arizona nonprofit corporation subject only to such limitations in the exercise of such powers as are expressly set forth in the Articles, the Bylaws, or this Declaration. The Association shall have the power to do any and all things which may be authorized, required or permitted to be done by the Association under this Declaration, the Articles and the Bylaws, and to do and perform any and all acts which may be necessary or proper for or incidental to the exercise of any of the express powers of the Association including without limitation the following:
- A. *Enforcement Actions.* Enforce in its own name, on its own behalf, or on behalf of consenting Owner(s) the provisions of this Declaration, the Articles, the Bylaws, and the Rules and Regulations by appropriate means, including, without limitation, the employment of legal counsel and the commencement and maintenance of actions at law or equity;
 - B. *Common Areas Administration.* Administer, maintain and otherwise manage all of the Common Areas, all improvements and landscaping, and all other property acquired by the Association;
 - C. *Property Taxes.* Pay any real and personal property taxes and other charges assessed against the Common Areas;
 - D. *Utility Contracts.* Obtain, as may be appropriate and necessary for the benefit of all of the Property, water, gas, sewer, telephone, trash, garbage collection and electric services and refuse collections;
 - E. *Utility Facilities.* Grant and convey to any third party easements and rights-of-way in, on, over or under the Common Areas for the purposes of constructing, erecting, operating or maintaining thereon, therein or there under (1) overhead or underground lines, cables, wires, conduits, or other devices for the transmission of electricity and for lighting, heating, power, telephone, community television,

radio and audio antenna facilities and for other appropriate purposes,

(2) public sewers, storm water drains and pipes, water systems, sprinkling systems, water, heating and gas lines or pipes, and (3) any similar public or quasi-public improvements or facilities;

- F. *Insurance.* Maintain such policy or policies of insurance as the Association deems necessary or desirable in furthering the purposes of and protecting the interest of the Association and the Owners;
- G. *Additional Funds.* Establish and maintain a working capital fund, capital improvement fund, and such other funds in such amounts as determined by the Association;
- H. *Contracts.* To expend Association funds, borrow money and execute such documents, mortgages, deeds of trust, security agreements, notes, contracts and other instruments as may be necessary or advisable for the purpose of performing the duties and exercising the rights granted to the Association;
- I. *Delegation.* Within the limits set by law, this Declaration, the Articles and Bylaws, establish such temporary or permanent committees (whether or not such committees are expressly provided for herein) as the Association in its discretion deems necessary and, if deemed appropriate by the Association, to delegate the Association's authority, duties and responsibilities to such committees.
- J. *Rules and Regulations.* Without approval of the Members, adopt reasonable rules and regulations concerning the use of the Property. These Association Rules shall be established and enforced uniformly so as not to discriminate for or against any Owner or Lot. Copies of the Association Rules shall be furnished by the Association to Owners upon request. In the event of any conflict in the provisions of this Declaration, the Articles, the Bylaws and the Association Rules, the provisions of the Declaration shall control, followed by the Articles, Bylaws and Association Rules in that order.
- K. *Owner Activities.* Conduct social, athletic and other events and activities to promote a recreational and leisurely lifestyle for Owners and guests.
- L. *Lien Foreclosure Bids.* Bid in any foreclosure sale affecting a Lot and to purchase, acquire, hold, lease, mortgage, and convey any Lot, provided that the expenditure of Association funds pursuant to such bid shall have been first approved by the vote of either (1) six of seven members of the Board of Directors, or (2) a majority of the Members who are voting on the matter. Notwithstanding the foregoing, no such approval shall be required for the Association to bid the amount of its judgment on foreclosure as the opening credit bid in any such sale,

regardless of whether the opening credit bid is the final bid or not.

M. *Further Acts*. Perform such other acts, whether or not expressly authorized by this Declaration, as may be necessary or appropriate to maintain and administer the Properties or to enforce or effectuate any provision of the Declaration, Bylaws and Association Rules.

- 7.2 Management. The Association may retain the services of a manager or management company to assist the Association in discharging its duties hereunder. In the event such a manager or management company shall be retained, such manager or management company shall be selected at the sole discretion of the Association and shall be retained pursuant to such management contract as the Association shall, in its sole discretion, deem reasonable and necessary. A copy of all management agreements shall be made available to each Owner by the Association upon request. Any agreement may be canceled and terminated pursuant to its terms by the Association. Any management agreement may be terminated by a vote of Members representing at least sixty percent (60%) of the total votes in the Association. No management agreement shall be for an initial or renewal term longer three (3) years.
- 7.3 Emergency Powers. The Association or any person authorized by the Association has the right but not the obligation to enter upon any Lot in the event of any emergency involving potential danger to life or property.
- 7.4 Member Actions. For any action requiring a vote of the Members, the Members may act by vote at the Annual Meeting or a Special Meeting of the Association called for such purpose, by a written ballot process as authorized by Arizona law at A.R.S. § 10-3708 as the same may be amended from time to time, or by a written consent process as authorized by Arizona law at A.R.S. § 10-3704 as the same may be amended from time to time.

PART 8

Duties of the Association

- 8.1 Duties. It shall be the duty of the Association to:
- A. *Common Areas Maintenance*. Maintain, reconstruct, repair, replace or refinish any Improvement, street, curb, gutter, landscaping, structure, parking area, fixture or facility located on the Common Areas or any portion thereof in accordance with (a) the last plans thereof approved by the Association, (b) the original plans for development of the Property, or (c) if neither (a) or (b) is applicable and if such improvement was previously in existence, then in accordance with the original designs, plans, finishing or standards of construction of such Improvement as it was originally constructed;
 - B. *Landscaping*. Replace or remove injured and diseased trees or other vegetation on the Common Areas, and plant trees, shrubs and ground

- cover to the extent that the Association deems necessary for the conservation of water and soil or for aesthetic purposes;
- C. *Signs, Markings and Lights.* Place and maintain upon the Common Areas such signs, markers and lights as the Association may deem appropriate for the proper identification, use and regulation thereof; repaint striping, markers, directional signs, etc., as necessary; clean and re-lamp lighting fixtures as needed;
 - D. *Trash Removal.* Remove all papers, debris, filth and refuse from the Common Areas and wash or sweep paved areas as required;
 - E. *Property Taxes.* Pay all real estate and personal property taxes and assessments on the Common Areas;
 - F. *Utility Payments.* Pay all electrical, water, gas, sewer, trash collection, telephone and other utility charges or fees for services furnished to the Common Areas;
 - G. *Insurance.* Pay for and keep in force at the Association's expense, (i) Workmen's Compensation Insurance to the extent necessary to comply with any applicable laws, and (ii) public liability, casualty, and fire insurance naming the Association as the insured with companies acceptable to the Association covering the Common Areas, all in amounts established from time to time by the Association;
 - H. *Fidelity Bonds.* Pay for and keep in force standard fidelity bonds covering persons authorized to sign checks on behalf of the Association or to receive or disburse funds or other property of the Association, in such amounts as the Association may determine from time to time; and
 - I. *Further Acts.* Do all such other and further acts which the Association deems necessary to preserve and protect the Common Areas and the beauty thereof, in accordance with the general purposes for use and enjoyment of the Property described in this Declaration.

- 8.2 Accounting. The Association shall at all times keep true and correct records of account for the Common Areas and the Association in accordance with generally accepted accounting principles applied on a consistent basis and shall furnish for the inspection of all Owners at reasonable times such records which shall specify in detail all expenses incurred and funds accumulated from Assessments or otherwise. If a management agent contracts with the Association to perform all or part of the Association's duties, the management agreement therefore shall require such management agent to maintain records in accordance with the foregoing requirements and to provide the Association with a report of its activities under such management agreement prior to the close of each fiscal year of the Association and at such additional times as may be requested by the Association. The information set forth in such report shall be included in the annual budget and report from the Association to the Owners.

PART 9

Covenants for Assessments

- 9.1 Creation of the Lien and Personal Obligation of Assessments. Each Owner by taking title to a Lot covenants and agrees to pay to the Association Regular Annual Assessments, Supplementary Assessments, Special Assessments, and such other Assessments as may be fixed, established and collected from time to time as herein provided (collectively, the "Assessments"). The Assessments, together with interest, reasonable late fees, and reasonable attorneys' fees, costs and expenses, shall be a charge on the Owner's Lot and shall be a continuing lien upon the Lot against which each such Assessment is made. Each such Assessment, together with interest, and reasonable attorneys' fees, costs and expenses, shall also be the personal obligation of the person who was the Owner of such Lot at the time when the Assessment fell due. The personal obligation for delinquent Assessments shall not pass to a successor in title unless expressly assumed by said successor. Without the approval of the Association, Lots shall not be sold, transferred or conveyed by any Owner without all Assessments having been paid in full, whether or not a Notice of Assessment Lien has been filed or recorded.
- 9.2 Use of Assessments. Assessments shall be disbursed solely for the exercise and performance of expressly stated Association powers and duties and for such other and further expenses relating to any services or facilities which may be necessary, advisable or expedient in order to carry out the intent, purposes and objectives of the Association as set forth in this Declaration. Each Lot shall bear an equal portion of the Common Expenses of operating the Property including the Common Areas.
- 9.3 Regular Annual Assessments. Except as otherwise provided herein, the amount of Regular Annual Assessments shall be determined by the Association after giving due consideration to the current maintenance costs and further needs of the Association, including maintaining an adequate capital improvement fund for repairs and replacement of those Common Areas that require replacement on a periodic basis. Not later than sixty (60) days prior to the beginning of the fiscal year the Association shall estimate the total Common Expenses to be incurred for the forthcoming fiscal year. The Association shall then determine the amount of the Regular Annual Assessment against each Lot. Written notice of the annual Regular Annual Assessment shall be sent to every Owner no later than thirty (30) days prior to the date the first payment based upon such Regular Annual Assessment is due. Notwithstanding anything foregoing to the contrary, in no event shall Regular Annual Assessments for any budget year increase from the preceding year by more than the greater of six percent (6%) or the increase in the Metropolitan Phoenix Consumer Price Index (All Items) computed by the Bureau of Business and Economic Research, College of Business Administration, Arizona State University, without the affirmative vote of Members representing at least fifty-five percent (55%) of the Members who are voting on the matter. If the Bureau of Business and Economic Research should cease computing a Metropolitan Phoenix Consumer Price Index (All

Items), the Consumer Price Index for all Urban Consumers (CPI-U) computed by the United States Department of Labor, Bureau of Labor Statistics, shall be utilized in its place for the purposes of this Section. Unless otherwise determined by the Association to be payable on a different schedule, the Regular Annual Assessment shall be payable in equal monthly installments, and each Owner shall pay to the Association the Regular Annual Assessment installment on or before the day of each month determined by the Association to be the monthly due date for Regular Annual Assessment installments. (Amended 02/16/2011 AGM)

- 9.4 Insufficient or Excessive Assessments. In the event the Association shall determine that the estimate of total charges for the current year is, or will become inadequate to meet all Common Expenses for any reason, it shall promptly determine the approximate amount of such inadequacy and issue a Supplementary Assessment. In the event the Association shall determine that the approximate amount collected or to be collected through Regular Annual Assessments is in excess of the Association's needs for the current year and reserves appropriate for future years, the Association, in its discretion, may refund to the Members who paid such assessments all or any portion of such excess, reduce the amount of the Regular Annual Assessments or abate Assessments as it deems appropriate.
- 9.5 Default Minimum Assessment. If the Regular Annual Assessment amount for any fiscal year is not made by the Association at least thirty (30) days in advance of the commencement of the fiscal year, then the Regular Annual Assessment then in effect, shall be automatically deemed to be the Regular Annual Assessment for the next year and assessed against each Lot and such Regular Annual Assessment shall remain in effect until the Association determines the Regular Annual Assessment for the new fiscal year and gives thirty (30) days written notice of the new Annual Assessment to each Owner.
- 9.6 Capital Improvement Fund and Repair/Reserve Funds.
- A. The Association shall establish and maintain (i) an adequate Capital Improvement Fund for periodic improvements to the Common Areas and for any other purpose deemed appropriate by the Association and (ii) a Repair/Reserve fund for the periodic repair of or replacements to the Common Areas and for any other purpose deemed appropriate by the Association. Contributions to these funds shall be included as part of the Regular Annual Assessments for Common Expenses.
 - B. As an additional funding source for the Capital Improvement Fund, each new Owner who purchases a Lot shall pay to the Association immediately upon becoming the Owner of the Lot a sum equal to six (6) months of the then current Regular Monthly Assessment for the Lot. Funds paid to the Association pursuant to this Section shall be placed in the Capital Improvement Fund. Payments made pursuant

to this Section shall be nonrefundable and shall not be considered as and advance payment of any Assessments levied by the Association pursuant to this Declaration. (Revised 02/20/2019 AGM)

- 9.7 Working Capital Fund. Additionally, a Working Capital Fund shall be established by the Association for the Common Areas operation, which at all times shall be equal to not less than one (1) months estimated Common Expenses for each Lot.
- A. The Association shall establish and maintain a Working Capital Fund for the purpose of ensuring that the Association will have cash available to meet unforeseen expenditures or to acquire additional equipment or services deemed to be necessary or desirable by the Association. The Working Capital Fund shall be maintained in a segregated account for the use and benefit of the Association. The Association shall endeavor to maintain the Working Capital Fund at an amount not less than one (1) month of the Association's Common Expenses.
- 9.8 Supplementary Assessments. In addition to the Regular Annual Assessments, the Association may levy in any fiscal year, or portion thereof, a Supplemental Assessment applicable to that year, or portion thereof, only, for the purpose of defraying either (a) Common Expenses which are expected to exceed or which in fact exceed Common Expenses, including, but not limited to, administrative expenses, expenses associated with holding annual or special meetings and similar expenses which were previously budgeted under a Regular Annual Assessment during any given fiscal year, or (b) for the purpose of defraying, in whole or in part, the cost of any construction or replacement of a Capital Improvement upon the Common Areas not covered elsewhere in this Declaration, including the necessary fixtures and personal property related thereto. To the extent any proposed Supplementary Assessment exceeds One Hundred Dollars (\$100.00) times the total number of Lots, such Supplemental Assessment must be approved by Members representing at least fifty-five (55%) of Members who are voting on the matter. (Amended 02/16/2011 AGM)
- 9.9 Special Assessments. In addition to Regular Annual Assessments and Supplementary Assessments, the Association may levy from time to time Special Assessments against a particular Owner and Lot for the purpose of collecting expenses, costs, attorney's fees and other amounts permitted hereunder to be chargeable to an Owner or Lot. In the event that the need for maintenance, replacement, or repair of any portion of the Common Areas results from the act or omission of an Owner or a member of his family, or his tenants, guests, licensees or invitees, the cost of such maintenance, replacement or repair shall also be added to and become part of a Special Assessment to which such Owner's Lot shall be subject.
- 9.10 Inadequate Assessments and Increase in Assessments. Each Owner shall

be personally responsible for becoming familiar with the financial records and condition of the Association and the costs of maintaining, repairing and operating the Property and shall not rely on the representations of the Association or any other person as to whether Assessments are or will be sufficient to cover past, present or future obligations of the Association.

- 9.11 Uniform Rate of Assessment. Both Regular Annual Assessments and Supplementary Assessments must be fixed at a uniform rate for all Lots and may be collected on a monthly, quarterly or annual basis, as determined by the Association.
- 9.12 Assessment Status Certificates. The Association shall, upon demand, and for a reasonable fee not to exceed Twenty Dollars (\$20.00), furnish a certificate signed by an officer of the Association setting forth whether the Assessments on a specified Lot have been paid and the current amount owing, if any.
- 9.13 Interest on Delinquent Assessments. Any Assessment not paid when due shall accrue a late fee determined from time to time by the Association for each month such Assessment is not paid. In addition, all delinquent Assessments, including applicable late fees, shall bear interest at the rate of eighteen percent (18%) per annum, compounded at the rate of 1.5% per month, or the highest rate permitted by the then applicable law, whichever is greater. All late fees and interest on delinquent Assessments shall be considered Assessments for all purposes herein.
- 9.14 Effect of Nonpayment of Assessments. In the event of a default in payment of any Assessment, the Association may enforce each such obligation in any manner provided by law or in equity, or without any limitation of the foregoing, by any or all procedures described herein.
- 9.15 Enforcement by Suit. The Association may cause a suit at law to be commenced and maintained in the name of the Association against an Owner or Member to enforce each such Assessment obligation without waiving any lien rights it may have against said Owner's Lot.
- 9.16 Action for Future Assessments. Any suit or action brought by the Association against a defaulting Owner shall, at the election of the Association, extend to all claims and demands against the defaulting Owner, whether matured or unmatured, and it shall not be necessary for the Association to bring additional suits or actions to collect claims not matured at the time of filing of such suit, but maturing subsequent to the filing thereof, while such action is pending.
- 9.17 Evidence of Lien. It shall not be necessary to the validity, enforceability or binding effect of any lien imposed by authority of this Declaration that it be evidenced by a recorded document other than the 1984 Declaration. It shall be sufficient to establish the amount of the lien in a

suit for collection, lien foreclosure or other action that the complaint describe the unpaid Assessment(s) with particularity and that a notice of pending litigation ("lis pendens") in the usual form be recorded. Notwithstanding other provisions of this section, a certificate stating the amount of any unpaid Assessment, acknowledged and recorded by an officer or designated agent of the Association, shall be prima facie evidence of the amount of the lien as the date of such certificate's recording.

- 9.18 Priority of Lien. Liens imposed on any Lot by this Declaration shall be prior to all other liens, interests and encumbrances on a Lot, except (1) liens and encumbrances recorded before the recordation of the 1984 Declaration, (2) a recorded first mortgage or first deed of trust on a Lot, or (3) liens for real estate taxes and other governmental assessments or charges against a Lot. Sale or transfer of any Lot shall not affect the Assessment lien. However, the sale or transfer of any Lot pursuant to a first mortgage foreclosure, or a first deed of trust-trustee sale shall extinguish the lien of such Assessment as to payments which become due prior to such sale or transfer. No sale or transfer, including the sale or transfer of any Lot pursuant to a first mortgage foreclosure or a first deed of trust-trustee sale shall relieve such Lot from liability for any Assessments thereafter becoming due.
- 9.19 Enforcement of Lien. Any such lien may, at the election of the Association, be foreclosed by appropriate action in court in the manner provided by law for the foreclosure of a realty mortgage as set forth by the laws of the State of Arizona, as the same may be amended from time to time. In the event of such foreclosure, the Association shall be entitled to recover from the defaulting Owner its reasonable attorneys' fees, expenses, court costs, title search fees, interest and all other costs and expenses incurred in connection with the foreclosure. Each Owner, by becoming an Owner of a Lot, hereby expressly waives any objection to the enforcement and foreclosure of this lien in this manner.

PART 10 **Architectural Review**

- 10.1 Obligation to Submit Exterior Plans for Approval. No landscaping, painting, installation or refurbishment of the exterior of any Recreational Vehicle, Park Model, or Improvement, including buildings, fences, walls, windows, storage facilities, entryways, vestibules, stairways, awnings, patio covers, window coverings or treatments, antennas, balconies or patios, nor any exterior attachment to or change or alterations thereof or change to the color of any such structure, or other structure or Improvement shall be commenced, erected or maintained upon the Property or any portion of a Lot, Visible from Neighboring Property (collectively, an "Exterior Change") without the prior written approval of a review committee (the "Architectural Review Committee")

established by the Association for the purpose of reviewing plans for Exterior Changes for the Property. The Architectural Review Committee may promulgate rules and regulations governing the procedures and guidelines for obtaining approval of the Architectural Review Committee.

- 10.2 Submission of Plans. An Owner seeking the Architectural Review Committee's approval shall submit plans and specifications sufficient to enable the Architectural Review Committee to understand the nature, kind, size, areas, height, materials, exterior color and surface, shape and design and location of the proposed Exterior Change.
- 10.3 Standard for Approval. Approval of a proposed Exterior Change may be denied if the proposed Exterior Change is not suitable or desirable with respect to the individual Property as a whole, taking into consideration the requirements of this Declaration, the aesthetics of the proposed Exterior Change, the harmony thereof with the surroundings, the effect on the view of adjacent or neighboring Lots and the effects on the Property as a whole.
- 10.4 Delayed Approval. If the Architectural Review Committee fails to approve or disapprove plans and specifications properly submitted for its approval within thirty (30) days after delivery, approval by the Architectural Review Committee shall be deemed to have been given unless, within the thirty (30) day period one or more members of the Architectural Review Committee gives written notice to the Owner of the need for an additional fifteen (15) day period to study the proposed construction, or if the Association sends the Owner a written request for additional information about the proposed Exterior Change to aid the Architectural Review Committee in determining whether a particular Exterior Change should be approved or not. In the event of this latter occurrence, the thirty (30) day review period shall restart upon the Architectural Review Committee's receipt of the additional information.
- 10.5 Waiver. The approval by the Architectural Review Committee of any plans, drawings or specifications for any proposed Exterior Change, or for any other matter requiring the approval of the Architectural Review Committee, shall not be deemed to constitute a waiver of any right to withhold approval of any similar plan, drawing, specification or matter subsequently submitted for approval.
- 10.6 Liability. Neither the Board, the Architectural Review Committee nor any member thereof, shall be liable to the Association, an Owner, or to any other party for any damage, loss or prejudice suffered or claimed on account of the good faith approval or disapproval of any plans or drawings, or the performance of any work, whether or not pursuant to approved plans, drawings and specifications.
- 10.7 Changes to Plans. No changes or deviations in or from such plans and

specifications once approved shall be made without the prior written approval of the Architectural Review Committee. Except for such appeal rights as may be expressly granted by the Association Rules, all decisions of the Architectural Review Committee shall be final.

PART 11 **Insurance**

- 11.1 **Terms.** All insurance policies shall, if possible, contain clauses waiving subrogation against Owners, the Association, and guests. As to each of said policies which will not be voided or impaired thereby, the Owners hereby waive and release all claims against the Association, the Board, and agents and employees of each of the foregoing, with respect to any loss covered by such insurance, whether or not caused by negligence of or breach of any agreement by said persons, but only to the extent of insurance proceeds received in compensation for such loss.
- 11.2 **Additional Insurance.** The Association shall have the authority to obtain such other insurance as it may deem appropriate or necessary, including, but not limited to fidelity bonds or other coverage, worker's compensation and officers' and directors' liability insurance. The Association shall annually determine whether the amounts and types of insurance it has obtained provide adequate coverage for the Common Areas in light of increased construction costs, inflation, practice in the community in which the Common Areas are located, or any other factor which would indicate that either additional insurance policies or increased coverage under existing policies are necessary or desirable to protect the interests of the Association. The Association shall obtain any such increased coverage or additional insurance found to be appropriate.
- 11.3 **Premiums and Proceeds.** Insurance premiums for insurance coverage obtained by the Association shall be a Common Expense to be included in the Regular Annual Assessments levied by the Association. Insurance proceeds shall be used by the Association for the repair or replacement of the Property for which the insurance was carried. The Association is hereby granted the authority to negotiate loss settlements with the appropriate insurance carriers. Any two (2) directors of the Association may sign a loss claim form and release form in connection with the settlement of a loss claim and such signatures shall be binding on the Association and its Members.

PART 12 **Enforcement**

- 12.1 **Rights of Enforcement.** The Association, or any Owner, shall have the right but not the obligation, to enforce, by any proceeding at law or equity, all restrictions, conditions, covenants, reservations, liens and charges now or hereafter imposed by the provisions of this Declaration. Failure by the

Association or by any Owner to enforce any covenant or restriction herein contained shall in no event be deemed a waiver of the right to do so thereafter. The failure to employ any remedy on any one or more occurrences giving rise to such remedy shall not be a waiver of the right to thereafter employ such remedy.

- 12.2 Suspension of Voting and Common Areas Rights. The Association shall have the right to suspend an Owner's voting rights and the Common Areas use rights for any period during which that Owner's Assessments or other monetary obligations remain delinquent. The Association shall have the right to suspend an Owner's Common Areas use rights for any period during which a non-monetary infraction of this Declaration, the Bylaws or the Association Rules remains uncured.
- 12.3 Recorded Notice of Violation. The Association shall have the right to record a written notice of violation of this Declaration. A copy of the notice of violation shall also be personally delivered or mailed to the last known address of the Owner. Recordation of the notice shall serve for all purposes as notice to the Owner and to any subsequent purchaser of the Lot that there is a violation of the provisions of this Declaration. The Association may charge a reasonable fee for its costs incurred in investigating the violation, preparing the notice, obtaining legal advice in connection therewith and recording and other fees. Neither the Association, the Board, the officers, or agents thereof shall be liable to any Owner or prospective or subsequent Owner for the failure to record any notice or liable for the erroneous recording of such notice if the recording was made or done based upon a good-faith belief that a violation had occurred.
- 12.4 Contents of Notice. The notice shall be executed and acknowledged by any officer or other agent of the Association and shall contain substantially the following information:
- A. The name of the Owner;
 - B. The legal description of the Lot against which the notice is being recorded;
 - C. A brief description of the nature of the violation;
 - D. A statement that the notice is being recorded by the Association pursuant to this Declaration; and
 - E. A statement of the specific steps which must be taken by the Owner to comply with this Declaration or the applicable rule.
- 12.5 Release of Notice. If after the recordation of a notice of violation the Association determines that the violation referred to in the notice does not exist or has been cured, the Association shall record a notice of compliance which shall state the legal description against which the notice of violation was recorded, the recording data identifying the Docket and page where the notice of violation was recorded, and shall state that the notice of violation is no longer in effect.

- 12.6 Violations and Nuisance. Every act or omission whereby any provision of this Declaration is violated in whole or in part is hereby declared to be a nuisance and may be enjoined or abated, whether or not relief sought is for negative or affirmative action by the Association or any Owner.
- 12.7 Self Help. To the extent permitted by law, the Association, the Board, and their duly authorized agents may also enforce by self-help any of the provisions of this Declaration, the Articles, Bylaws and Association Rules.
- 12.8 Covenants Cumulative. The remedies, rights, obligations and restrictions described in this Declaration are cumulative and may be enforced individually or jointly and in any order.
- 12.9 Attorneys' Fees. The prevailing party in any action to enforce this Declaration or the Articles, Bylaws or Association Rules shall be entitled to recover his costs and reasonable attorneys' fees, costs, and other expenses.

PART 13
Right of First Refusal

- 13.1 Ownership Subject to Right of Refusal. Each Lot shall at all times be subject to a right of first refusal in favor of the Association as herein described.
- 13.2 Sales Only After Bona Fide Offers. No Lot shall be transferred in any manner except by the Owner's acceptance of an offer (the "Bona Fide Offer") in writing, signed by an offerer or offerers (collectively the "Offerer") financially capable of carrying out the terms of such Bona Fide Offer, in a form legally enforceable against the Offerer and not inconsistent with this Declaration or the Articles, Bylaws or Association Rules. The transfers described in the preceding sentence shall include any lease for more than a ten (10) year period (including extensions) and every other sale, transfer or conveyance (other than by bona fide gift or devise to a lineal descendent of the Owner's natural or adoptive parents and without actual consideration therefore) but shall not include any lien foreclosure sale provided notice of said foreclosure sale is given to the Association at least ten (10) days prior to the sale.
- 13.3 Notice of Offer. No Owner shall accept a Bona Fide Offer for the sale of any Lot without first giving notice to the Association and offering to sell said Lot to the Association at the same price and upon the same terms and conditions as are contained in the Bona Fide Offer. The notice of a Bona Fide Offer shall contain a true and complete copy of the Bona Fide Offer, setting forth the price and all terms and conditions, with the name, proof of age, and home and business addresses and phone numbers of the

Offeror.

- 13.4 Acceptance by Association. For a period of five (5) days from the Owner's giving of notice to the Association of a Bona Fide Offer, the Association shall have the right, at its sole option, to purchase the Lot so offered for the same price and upon the same terms and conditions set forth in the Bona Fide Offer. Such election must be exercised by giving notice thereof to the Owner.
- 13.5 Rejection by Association. If the Association does not timely elect to accept a Bona Fide Offer, the Owner shall have the right to accept the Bona Fide Offer in whole (but not in part) but only in strict accordance with all of the provisions of the Bona Fide Offer and only if the sale is fully consummated within one (1) year of the Owner's notice to the Association. Any change in the Bona Fide Offer or the failure of the transaction described therein to close within one (1) year of the Owner's notice to the Association shall be deemed to be the Owner's rejection of the Bona Fide Offer and no Bona Fide Offer shall thereafter be accepted until the Owner again complies with the first right of refusal provisions of this Declaration.
- 13.6 Closing of Sale to Association. The closing and settlement of any transaction resulting from the Association's acceptance of a Bona Fide Offer shall, notwithstanding any provision of the Bona Fide Offer to the contrary, take place at the main office of the Association within thirty (30) days after notice of the Bona Fide Offer by the Offering Owner. At such time the Association shall deliver to the Offering Owner the consideration required under the terms and conditions of the Bona Fide Offer. Simultaneously, the Offering Owner shall deliver to the Association a general warranty deed transferring to the Association fee simple title to the offered Lot, subject only to any term and condition of the Bona Fide Offer.
- 13.7 Association Authority. The Association is expressly authorized to use Association funds to purchase any Lot pursuant to this Article 13.
- 13.8 Lease-Purchase Agreements. Owners are expressly authorized to enter into leases with provisions requiring or allowing the purchase by the lessee of the Lot leased. The mere creation of a leasehold interest pursuant to such a lease does not, unless the lease term (including extensions) exceeds ten (10) years, constitute a transfer governed by the first right of refusal provisions of this Declaration. However, the attempted exercise or performance of any such right or obligation to sell or purchase shall constitute a proposal to transfer the Lot and such transfer shall not occur except by Bona Fide Offer in accordance with the first right of refusal provisions and other provisions of the Declaration.

PART 14
General Provisions

- 14.1 Purposes of Declaration. This Declaration is declared and agreed to be in furtherance of a general plan for the subdivision, improvement and sale of the Property and is established for the purpose of enhancing and perfecting the value, desirability and attractiveness of the Property and every part thereof.
- 14.2 Running with the Land. All of this Declaration shall run with all of the Property for all purposes and shall be binding upon and insure to the benefit of the Association and all Owners and their successors in interest.
- 14.3 Severability. Invalidation of any provision of the Declaration or the Articles, Bylaws or Association Rules by judgment or court order shall not affect any other provisions thereof, which shall remain in full force and effect.
- 14.4 Construction. This Declaration and the Articles, Bylaws, and Association Rules shall be construed according to their clear and obvious intent in such a manner as to promote and secure the appearance, integrity, value, and operation of the Property as a whole. Paragraph headings have been inserted for convenience only and shall not be considered or referred to in resolving questions of interpretation or construction.
- 14.5 Term. The covenants, conditions and restrictions of this Declaration shall be enforceable for a term of fifty (50) years from the date this Declaration is recorded, after which time said covenants, conditions and restrictions shall automatically be extended for successive periods of ten (10) years.
- 14.6 Amendments. This Declaration may be amended in whole or in part at any affirmative vote of the Members representing at least sixty (60%) percent of the total votes in the Association Certificate of Amendment executed and acknowledged by the President and the Secretary of the Association, certifying the facts of a vote duly held at which the required number of Members affirmatively for the adoption of the amendments. (02/24/1998 AGM)
- 14.7 Singular Includes Plural. Whenever the context of this Declaration requires, the singular shall include the plural and references to any gender shall include all genders.
- 14.8 Perpetuities and Other Invalidity. If any of the privileges, covenants or rights created by this Declaration would otherwise be unlawful or void for violation of (a) the rule against perpetuities or some analogous statutory provisions; (b) the rule restricting restraints on alienation; or (c) any other statutory or common laws rules imposing similar time limits, then

such provision shall continue only until twenty-one (21) years after the death of all of the survivors of the now living descendants of Donald Trump, President of the United States and Katie Hobbs, Governor of the State of Arizona.

- 14.9 Violation of Law. Any violation of any state, municipal, or local law, ordinance or regulation, pertaining to the ownership, occupation or use of the Property by any Owner is hereby declared to be a violation of the Declaration and subject to any or all of the enforcement procedures set forth in said Declaration.
- 14.10 Delivery of Notices and Documents. Any written notice or other documents relating to or required by this Declaration may be delivered either personally or by mail. Mailed notices shall be deemed to have been delivered seventy-two (72) hours after a copy of same has been deposited in the United States mail, postage prepaid, addressed as follows: If to the Association, at 7750 East Broadway, Mesa, Arizona 85208; if to an Owner, to the address of his Lot or to any other address last furnished by the Owner to the Association for purposes of receiving notices. Any address for giving of notice may be changed at any time giving the Association notice of the new address. Each Owner is responsible to ensure that the Association has the correct mailing address of such Owner and shall promptly notify the Association in writing of any error in the Owner's address or any subsequent change of address. (Revised 02/25/2026 AGM)
- 14.11 Covenant by Owners. By acceptance of a deed or by the acquiring of any ownership interest in any of the real property subject to this Declaration, each Owner, for himself or itself, his heirs, personal representatives, successors, transferees and assigns, binds himself, his heirs, personal representatives, successors, transferees and assigns, to the provisions, restrictions, covenants, conditions, rules, and regulations now or hereafter imposed by this Declaration, the Articles, Bylaws, and Association Rules, and any amendments thereto. In addition, each Owner by so doing thereby acknowledges that this Declaration and the ancillary instruments set forth a general plan and design for the improvement and development of the Property covered thereby and such Owner evidences his intent that all the restrictions, conditions, covenants, rules and regulations contained herein shall run with the land and be binding on all subsequent and future Owners, grantees, purchasers, assignees, and transferees thereof. Furthermore, each such person fully understands and acknowledges that this Declaration shall be mutually beneficial to and enforceable by the various subsequent and future Owners.

CARRIAGE MANOR RV RESORT ASSOCIATION, INC.
DESIGN GUIDELINES

PART 1
Purpose

- 1.1 Declaration Authority. The Carriage Manor Resort's Governing Documents, Declaration of Covenants, Conditions and Restrictions (CC&R's) and Rules and Regulations allow for architectural guidelines. It is the responsibility of the lot owner to comply with the current Design Guidelines. The purpose of the guidelines is to assist the owner in achieving the desired level of individual and esthetic lot design, while being consistent with the overall design concept of Carriage Manor RV Resort's Design Guidelines and Codes as required by local, state and federal agencies applicable for the type of building or improvement proposed.
- 1.2 Supplement Declaration. These Design Guidelines do not supersede, but rather supplement the CC&R's, and the specific requirements and parameters included therein shall apply. The goal of the CC&R's is to insure development of a consistently high quality environment, thus protecting and enhancing the safety and investment of all Carriage Manor RV Resort owners and residents. The Architectural Review Committee (ARC) has been established and serves at the discretion of the Board of Directors. The ARC maintains reasonable procedures, rules and regulations to assure owner compliance with the guidelines.
- 1.3 Deviations. Requests for deviations or variances from the guidelines may only be granted by the Board of Directors and will only be processed at a regularly scheduled meeting and will be considered for approval on being aesthetically pleasant and/or an asset to the sub-division.
- 1.4 Amendment to Guidelines. The Design Guidelines which may be amended from time to time by the Architectural Review Committee (and approved by the Board of Directors) are intended to aid the owner in achieving a style, character and quality of development conforming to the goals and objectives for Carriage Manor RV Resort as illustrated in the CC&R's. The Design Guidelines are a model for lot improvement; they are reasonably flexible and are intended to provide opportunities for creative, high quality development. It is the responsibility of the owner to comply with the Design Guidelines.

- 1.5 Code Compliance. The ARC will attempt to assist owners in complying with city, state and federal codes. The issuing of a CM permit does not relieve the owner from compliance with all codes. It is still the full responsibility of the owners to determine that they do comply with all required codes.
- 1.6 Carriage Manor Limitations. Carriage Manor Design Guidelines may differ from Mesa city requirements and may be more restrictive than City of Mesa and the state of AZ regulations. In such cases the owners shall adhere to the most restrictive requirement. (CC&R's, 10.1 thru 10.7)
- 1.7 Insurance. We suggest that all owners doing any construction or building have insurance (Home owners) It is also suggested that an owner have \$300,000 liability coverage. It is an owner's responsibility to insure that the manufacture, dealer, contractor and sub-contractor be licensed, insured and bonded. (See RR #12.14)
- 1.8 Permits. In general permits are required for all exterior changes or improvements, (Construction, Landscaping, TV satellite dishes and Antennas etc.) (CC&R's 10.1 R&R 8.1)

PART 2

Permit Procedures

- 2.1 Required Forms.
 - A. A Carriage Manor Permit Form may be obtained at the front desk. When filled out the application should include detailed information on the project. If it is for a building see sections the project is related too. Park Models 4.9, Manufactured Housing 4.10, Awnings 4.12, Storage Structures 4.13, Raised Decks 4.14, Patio Enclosures (AZ- Rooms) 4.15 Removal of all or any structures 4.8 The application should include site and building dimensions Material descriptions plans, elevations etc. Any changes of plans or specifications must be submitted to the ARC for approval. (CC&R's 10.1, 10.2, 10.3, 10.7, R&R's 8.4)

If it is for other than building construction see, Motor Homes 5th wheels and trailers 4.3 and 4.16 and after for landscaping etc.

 - B. A City of Mesa Building permit application packet is available from the office if required. A listing of improvements or additions that may require a permit is shown on Exhibit "H".
- 2.2 Submission Sequence.
 - A. Complete the C.M. application and permit for construction form and turn in to front desk. (ARC will process within 7 to 10 calendar days)

ARC will issue a permit (Green) and attach a sheet if needed to alert the owner to any issues concerning the project. Should the ARC fail to approve or disapprove plans and specifications property submitted for its approval within thirty (30) days after submitted, approval of said project shall be deemed to have been given unless, with the (30) day period one of more or more members of ARC gives a written notice to the owner of a need for additional fifteen (15) day period to study the proposed construction. (See CC&Rs 10.4).

- B. A city permit is required for projects noted on Exhibit “H”. The city will require a copy of Carriage Manors permit when you apply for the city permit. (See 2.1B & 4.9L)
- C. Return the green permit copy to the office when the project is completed.

PART 3 **Schedule Requirements**

- 3.1 Time Limits.
 - A. The project shall begin within 60 days of the date on which ARC grants approval. (If a permit is required for you project and the city permit process is delayed you shall submit a written request to ARC for an extension)
 - B. Projects must be completed within 90 days of the start of the project. (Delivery of materials or unit) (**PLEASE NOTE:** Time restrictions are generally for the purpose of preventing unsightly areas to exist for extended periods. C.M. time limits apply only to the exterior portion of the project) (**Revised 01/17/2007**)
 - C. Contractor & Owner hours of work except for emergencies approved by the Manager are 7:00 am – 5:00pm Monday -Saturday, with the following holidays prohibited: New Years Day, Memorial Day, Independence Day, Labor Day, Thanksgiving Day, and Christmas Day. (**R&R 12.16**) (**Revised 10/18/2023**)
(Summer Hours may be extended by special request and approval of the Management)
- 3.2 Permit Posting. All required permits must be displayed on the job before work may begin. RETURN PERMIT WHEN COMPLETE!
- 3.3 Non-compliance Levy of Fines. (see Rules & Regulations 15.2)
- 3.4 Levy of Fines.
 - A. After 60 days from beginning a project, a letter of warning.
 - B. After 120 days, a \$100.00 fine
 - C. After 180 days, a \$500.00 fine
 - D. After 240 days, Board Action will be taken. Upon application to ARC, special circumstances will be considered. Non-compliance fines maybe appealed to the B.O.D. (**Revised 01/17/2007**) (See Rules & Regulations 15.2B)

PART 4
Specific Project Guides

- 4.1 Paving and Grading.
- A. Asphalt is prohibited anywhere on the lot. Grading of the lots will not be modified without approval of the ARC.
 - B. No concrete is allowed in the setback area, except driveway. Driveway includes an existing or new concrete apron or flair allowing a car to easily access the driveway. (Revised 1/16/2008) (R&R 9.23)
 - C. All excess dirt and landscaping materials must be removed from the Resort by the contractor. (R&R 8.4)
 - D. A disposal fee will be charged for projects completed by the owner for the dirt and materials disposed. (See Rules & Regulations 8.4 for the fee schedule & regulations)
- 4.2 Setbacks - Easements.
- Lot Setbacks. Each lot shall be subject to a setback area across the front seven (7) feet, on both sides five (5) feet, and at the rear five (5) feet.
- A. All units must be in line at the front of the lot at 7'0”.
 - B. No permanent or temporary structures or improvements may encroach that area, other than landscaping, approved fence gates (See Design Guidelines 4.19), and vehicles like golf carts, and motorcycles. Passenger Cars/Trucks are prohibited. (AC units, & movable steps and prefab storage sheds (See Design Guidelines 4.13.1) are allowed in the rear setback area. See 4.11-B) (CC&R 3.27 & 4.2) (Revised 08/25/2021)
 - C. Motor Homes and 5th wheels over thirty-eight (38) but not more than forty (40) feet in length, which may be located on a lot for less than 300 days in any calendar year, shall be allowed to infringe upon the seven (7) foot setback by up to two (2) feet. (R&R 4.4F) (Revised 03/20/2019)
 - D. The location of a Park Model or a Manufactured Home on the lot other than the standard configuration (right side next to power pedestal) will require approval from ARC and a variance from the BOD. (Revised 03/20/2019)
 - E. Each lot must have a nine (9) ft. by twenty (20) ft. unobstructed vehicle parking area (from the 7'0” street set back). (Exhibit G) (Revised 03/20/2019)
 - F. Any item placed within a setback that must be removed will be done at the owner's expense.
 - G. Any damages to utilities or the utilities connections caused by a resident or guest shall be the financial responsibility of the lot owner.
 - H. The height of a Park Model or Manufactured Home cannot exceed 15'8” measured at the back of the lot. (Any variation of that must have ARC approval). (Revised 03/20/2019)
 - I. Roof over hangs cannot exceed 1'0” at the front and rear and (6) inches on the sides of the Park Model or Manufactured Home unless approved by ARC.(see 4.12-A for awnings) (Revised 03/20/2019)

- 4.3 Placement of Motor Homes, 5th Wheels & Trailers. Recreational vehicles must be located on the side of the lot which has the hose bib, sewer lines and electric pedestal (right side of lot). Any relocation of utilities requires ARC and BOD approval and are at the expense of the owner.
- A. The vehicle must be backed in with the "curb side" doorways facing the patio. A setback of seven (7) feet (set even with the patio concrete) from any portion of the recreational vehicle or park model, other than the trailer tongue, to the front of lot line, and a minimum setback of five (5) feet from any portion of the RV, & slide outs to the side or rear lot line is required. (See Section 4.2A and Exhibits A-1, A- 2 & B-3) See R&R 9.1 and 4.5
 - B. All hookups shall be to the receptacles provided on each Individual lot in accordance with the City of Mesa Building Code or manufacturer's specifications.
 - C. If wheel covers are used on either RV or transportation vehicle, they must be constructed of materials suitable for this usage. The use of cardboard, pieces of wood, Styrofoam, etc., are not in keeping with the beauty of the resort. If you use wheel covers not purchased at an RV supply store, you must get approval for design and material from the ARC. See R&R 5.6 (Revised 02/10/2016)
 - D. RV's over 10 years old are not allowed to enter the resort unless approved by the ARC and BOD. Approval must be applied for each year. (The RV may be subject to an inspection fee) See 4.1& 4.2 Rules & Regulations). (See CC&R 3.31)
- 4.4 Roofing. All fiberglass asphalt shingles and ribbed or rolled roofs on Park Models, Manufactured Housing, Sheds and patio enclosure must be neutral light color. (White or Gray) Other colors or material must be approved by the ARC. (Patio enclosures built under awnings are acceptable) Tile roofs are not allowed. (All colors must be approved by ARC) (Revised 02/10/2016)
- 4.5 Siding. All siding on Park Models, Manufactured Housing, Sheds, and Patio enclosures Accessory room must be horizontal and of yoder, aluminum, steel (galvanized), vinyl, ironwood, masonry based hardi board or approved equivalent. The color must be white, beige, or a neutral color. Any other color or material must be approved by the ARC. Trim may be of same material as siding or approved other (Exposed wood, Masonite, stucco & T-1-11 are not approved). (Revised 03/13/2013)
(All colors must be approved by ARC see CC&R 10.2)
- 4.6 Skirting. Each Park Model, Arizona Room, Manufactured Home and raised deck are required to have skirting around the entire perimeter of the structure. The skirting may be vertical or horizontal of vinyl, masonry based board or approved equivalent. (No carpet) Additionally, the front of the unit must have horizontal siding matching the unit or precast stone or brick on backer board not requiring a footing. The color must be a neutral color or color consistent with structure involved. A separate permit requiring material approval from the ARC Committee is required. All skirting shall be subject to ARC approval. (No carpet on drawer fronts no exposed wood)

- A. Skirting must be attached to a continuous concrete ribbon around the perimeter of the unit.
 - B. Access panels and air vents are required.
 - C. Park Models Manufactured Homes Arizona room additions and Decks must be skirted within forty-five (45) days of being set or start of construction
 - D. Exposed or painted wood is not allowed anywhere. (Revised 02/14/2018)
- 4.7 Steps. All steps including temporary and movable, into Park Models, Manufactured Homes, Decks and AZ rooms must meet City & State requirements for width of steps, riser heights, tread length, landing size, railing and handrail. Carpet is not allowed on steps. Exposed or painted wood is not allowed on steps or railings (composite material is suggested for steps). (Revised 08/17/2018)
- 4.7.1 Driveways. A permit is required to paint driveways. The color and or pattern should blend in with that of the site structure and surroundings. The selected color should be part of the permit request for ARC approval. (Adopted 02/10/2016)
- 4.8 Park Model Removal. Any park model removed from a lot in Carriage Manor must be removed in a timely manner to assure the lot is maintained in an acceptable appearance. A permit is required to remove a park model and shed. The owner of the lot shall be responsible to assure the appearance of the lot is acceptable to the Architectural Review Committee at all times. All structures and building material such as skirting, piers, and steps shall be removed from the lot within 30 days from the application date of the ARC permit. All bare ground to be covered with concrete, pavers or rock if not being used in 45 days. An extension to that time may be granted by the ARC. Fines, if any, shall be established by the Board of Directors based on the severity of the conditions. (Revised 02/10/2016)
- 4.9 Park Model Home.
- A. A park model is a unit that does not exceed thirty-eight (38) feet in length nor contains more than four hundred (400) square feet or less than 320 square feet of living space, including bay windows. Park Models or other RV's over ten (10) years may not be accepted. (See Rules & Regulations 4.1 Board approval is required) All Park Models must be approved before being placed in the park. Please see main office for permit forms and further information. (Park Model and Accessory structures aggregate floor area cannot exceed 920 sq. ft. attached or detached per lot) (4.13 & 4.15) (CC&R 1.14)
 - B. A permit is required from the ARC at a cost of \$100.00 prior to the unit being placed on a lot. The permit request must include the following: A site plan showing set back and easements, property lines and building location. (See 4.2 & Exhibit "G") The Park Model manufacturers list of construction specifications. A floor plan, elevation drawings all 4 sides, Roofing, Siding

and Skirting and Awning information see sections 4.4, 4.5, 4.6,4.7 and 4.12 (Material samples and other information may be requested prior to issuing a permit) Lots with SRP electrical transformers may require extra clearances. The owner is responsible to verify with SRP before proceeding (See Exhibit “J” for SRP information)

- C. The park model shall be installed on lot in its approved location in such a manner that the maximum height of the finished floor of the unit, as measured within two (2) feet of the front axle, shall not exceed thirty-four (34) or a minimum of (16) inches above the concrete patio. This maximum height does not include any increment of height resulting from the need to use shimming wedges to achieve proper leveling of the park model (See Exhibit “C”). Any deviation exceeding these measurements must be approved by the ARC.
- D. Setting and anchoring of the park model must comply with Industry standard practice as well as state & city codes. No wood posts are permitted. (See Exhibit “C” for setting Height & section 4.2F)
- E. Air conditioners and movable rear steps may extend into Public Utility Easement area at the rear of the lot only and on movable concrete pads. (see 4.11-B)
- F. The height of a Park Model cannot exceed 15’-8” in height measured at the back of the lot. (Any variation of that must have ARC approval)
- G. Should an owner desire to bring in an older Park Model it cannot be more than 10 years old and requires approval of the ARC & BOD and is Subject to a \$50.00 inspection fee and a \$ 100.00 permit fee.
- H. Any shed (Accessory building) on the lot with a Park Model must have the same siding as the Park Model. See 4.13 for shed requirements.
- I. Park Models must have 30% glass across the front of the unit and on corner lots to have 20% glass on the side measured from the floor to 6’-8” across the building.
- J. Insurance See 1.7
- K. Minimum parking space shall be 9 x 20 unobstructed and shall not be enclosed.
- L. Any structural exterior modification of a park model must be approved by Carriage Manor, the city and the manufacturer. **(Revised 03/13/2013)**
- M. The Manufacturer/Dealer/Contractor shall provide and install City & State approved steps at all door exits (front and back) of the unit as part of the contract with owner. Back steps must be movable. No temporary steps are allowed after 90 days from the delivery of unit. See (4.7) **(Adopted 02/10/2016)**

4.10 Manufactured Housing

- A. Manufactured housing may be any width or length that the lot can accommodate as long as all setbacks are met including allowances for vehicle parking, setting the unit, skirting and bay windows. The total roof area of all enclosed space (including the manufactured home, additions, storage rooms and patios) is capped at 1100 sq. ft. Placement of the manufactured home, all additions, open carports and porches shall comply with all building setbacks and codes.

- B. A permit is required from the ARC at a cost of \$100.00. The permit request must include the following: A site plan showing set back and easements, property lines and building location. (See 4.2 & Exhibit “G”) The Manufactured House manufacturers list of construction specifications a floor plan, elevations of all 4 sides of the unit, Roofing, Siding, Skirting and Awning information (see sections 4.4, 4.5, 4.6 and 4.7) (Material samples and other information may be requested prior to issuing a permit) Lots with SRP electrical transformers may require extra clearances. The owner is responsible to verify with SRP before Proceeding. (See Exhibit “J” for SRP information) *(Revised 02/10/2016)*
- C. Insurance See 1.7
- D. The front wall must have 30% glass and the side wall on corner lots must have 20%, measured from the floor to 6’ – 8’ height across the building. *(Revised 01/14/2015)*
- E. Setting and anchoring of the park model must comply with the Industry Standard practice as well as state & city codes. No wood posts are permitted. (See Exhibit “C” for setting Height & section 4.2F)
- F. An awning over the vehicle parking and patio area is required.
- G. The front wall of the home must look similar to a park model. (And be approved by ARC) To be consistent with the city’s residential guidelines and encourage variety in the development of the subdivision the city prohibits
 - 1) The placement of two identical elevations on adjacent lots or on lots across the street from each other.
 - 2) The placement of more than two identical elevations with different exterior colors within five consecutive lots on the same side of the street.
 - 3) Front entrances and porches are not allowed.
- H. The Manufacturer/Dealer/Contractor shall provide and install City & State approved steps at all door exits (front and back) of the unit as part of the contract with owner. Back steps must be movable. No temporary steps are allowed after 90 days from the delivery of unit. See (4.7) Decks and patio enclosures are permitted to attach to Manufactured homes. They require a permit from ARC and the City of Mesa. See 4.14 and 4.15. *(Revised 02/10/2016)*
- I. Lots in CM are provided with 100 amp electrical service. Additional service will be at the owner’s expense. (PERMIT IS REQUIRED)
- J. See Exhibit “K” which is a check list to assist in submitting a Manufactured Home permit application.
- K. Any shed (accessory building) on the lot with a Manufactured Home must have the same siding as the Manufactured Home.
- L. If a tag unit is provided with a Manufactured Home the front elevation must have 30 % glass.
- M. The height of a Manufactured Home cannot exceed 15’-8” in height measured at the back of the lot. (Any variation of that must have ARC approval)
- N. Air conditioners and movable rear steps may extend into Public Utility Easement area at the rear of the lot only and on movable concrete pads.
- O. Minimum parking space shall be 9 x 20 UNOBSTRUCTED and shall not be enclosed. *(01/14/2015)*

- P. The Manufactured Home floor line may be set at a maximum of 38” from the carport concrete surface. A minimum of 12” must be maintained between the lowest member of the frame and carport concrete surface. (Revised 12/13/2017)

4.11 Utilities.

- A. Any relocation of utilities requires ARC approval and are at the expense of the owner. (A permit is required) (Revised 01/14/2015)
- B. All air conditioners and evaporative coolers must be ground mounted at the rear of the Park Model and manufactured homes (on moveable concrete pad). Evaporative coolers, heating units, hot water heaters, compressors, solar panels, solar collectors, or similar devices shall not be erected, constructed, placed or installed or permitted on the roof of any Park Model, Manufactured Home or structure, unless the same has been approved in writing by the ARC.
- C. Satellite dishes one meter (39”) in size are allowed on Motor Home, 5th wheels & Travel Trailers. Permanent mounting on Park Models and Manufactured Housing is allowed. A permit is required from the ARC for temporary installations. The Application must show the location of the satellite and or TV antenna. It must be on the back of the unit and cannot Project over 4’-0” above the roof. Mounting In the easement is not allowed. Temporary installations may be placed in the rear of the lot only after approval of the ARC. A permit is required from the ARC for temporary installations. Satellite dishes and WiFi antennas mounted on roofs and awnings using pans and concrete blocks are not allowed (See CC&R 3.7 & R&R 12.2) See exhibit F for amateur radio requirements. A person staying 3 – 5 months is allowed to use a portable tripod to install satellite dishes but this must be removed when they leave. (Revised 03/16/2016)

4.12 Awnings. Patio awnings are permitted as long as they conform to the current City of Mesa Building Codes and to the following: Awnings are required on Park Models and Manufactured Housing over the vehicle parking & patio area. (See Exhibit “B”)

- A. Does not exceed the width of the patio and vehicle parking area, except for a six (6)-inch overhang.
- B. Must meet city and or state code (ICBO standards for posts, beams and awning thickness).
- C. A unitizing strip must be installed across the patio cover and Park Model and Manufactured home.
- D. The awning must be attached to the Park Model / Manufactured Home at the lowest point of the Park Model /Manufactured Home roof line where the two are adjoined. Any deviation must be approved by the ARC.
- E. Free-standing awnings are permitted only over the vehicle parking area. (See Exhibit “B”) (Revised 02/10/2016)
- F. Footing requirements for free standing awnings must meet City of Mesa and UBC codes (See Exhibit B & D)

- G. Maximum height for all awnings is fifteen (15) feet, eight (8) inches (15'8")
(Revised 06/16/2021)
- H. Insulated awning pans are approved.
- I. Window and eye brow awnings are approved; however, they may not protrude more than three (3) feet on the side, nor four (4) feet in the front. The bottom edge of the eyebrow awning must be at least seven (7) feet above the ground. Canvas type window awnings are approved if they meet these requirements. And they must be of one continuous color and may contain a trim color that coordinates with the color of the unit. Upon order of the Manager, such awnings shall be removed or replaced if it becomes unsightly. (Revised 06/16/2021)
- J. Carriage Manor and the City of Mesa permits are required for all patio awning installations or extensions. Also, the City of Mesa requires a stipulation from the awning company stating that the extension or revisions are in accordance with the manufacturer's specifications.
- K. Ramada roofs are not approved. A Ramada roof is a free-standing structure either permanent or temporary that provides a roof for shade or protection from the elements. Free standing awnings over vehicle parking area/carport are approved. (Revised 02/10/2016)
- L. Insurance See 1.7

- 4.13 Storage Structures. Are permitted so long as they meet the following requirements, and have a City of Mesa permit. (Revised 02/10/2016)
 - A. One shed per lot and must be placed on back half of lot. A shed May be attached to Park Model or Manufactured Home. A City of Mesa permit for such additions is required. No temporary structures are allowed. See CC&R 3.22. (Revised 01/14/2015)
 - B. Maximum floor size is 120 square feet. Minimum floor size is 32 square feet.
 - C. Prior to construction, detailed plans with type of construction framing description, all dimensions exterior siding material color and location on lot must be provided to the ARC for approval.
 - D. A city permit is required for any electrical or plumbing in the shed
 - E. Washers, dryers, showers and toilets are allowed in sheds (City of Mesa permit required for plumbing and electrical) (Revised 01/14/2015)
 - F. Siding See 4.5
 - G. Maximum wall height of eight (8) feet and a maximum total height of nine (9) feet above finished floor level if free standing. Ten (10) feet above finished floor level if beneath patio cover.
 - H. Sheds may be built to the underside of the awning if the city approves. A park model need not be present. (Revised 02/10/2016)
 - I. Sheds must be placed on solid concrete.
 - J. Shed may be with or without windows.
 - K. Must be tied down on all four (4) corners. (Stick built must be of conventional 2x4 construction and anchored to concrete)
 - L. Manufactured bolt-together sheds are not allowed.

- M. Any shed on the lot with a Park Model or Manufactured Home must have the same siding as the Park Model or Manufactured Home
- N. Insurance See 1.7
- O. A permit is required to remove a shed. (Revised 01/14/2015)

4.13.1 Vinyl Storage Sheds/Chests. Vinyl storage sheds are allowed with the following restrictions.

- A. A lot is limited to no more than two sheds/chests: each must not exceed the maximum size of 4 ½ ft. wide, 2 ½ ft. deep, and 7 ft. high.
- B. A shed/chest must be placed against the back of the park model or Arizona room and facing the property line. At least 2 ½ feet of space must remain between it and that lot line.
- C. The required ARC permit specifies the color and location as approved.
- D. The shed/chest may not be permanently attached to the unit or ground but may be attached to the unit by an easily removable device. (Adopted 03/20/2019)

4.14 Raised Decks. The owner may elect to use an open, raised deck or porch to compensate for the elevation of his RV; however the City of Mesa requires a city permit for all decks over 30” high.

- A. Maximum deck height not to exceed the floor height of the Manufactured Home or Park Model (See Exhibit “C”) Decks must comply with Exhibit I defining minimum construction details. The Owner shall provide an accurate drawing or print with measurements to show the construction of the proposed raised deck and railing. See 4.7 for step requirements. (Revised 08/17/2018)
- B. Shall have railings of metal or other approved material and shall comply with City of Mesa code. No exposed or painted wood is allowed. (Revised 08/17/2018)
- C. Must be skirted See 4.6. (Carpet skirting is not allowed). Carpet is not allowed on drawer fronts. (Revised 02/10/2016)
- D. The surface of the raised deck shall be tile, carpet or Composite material. (Not painted) Exposed or painted wood is not approved. Edges of deck must be metal, composite building material (example: Trex) or other approved material. Carpet is not allowed to extend to the edges or wrap over the edges of the deck. (Revised 08/17/2018)
- E. No exposed wood drawer front. (Revised 01/14/2015)
- F. Steps and railings on decks must comply with the city of Mesa building code. (See 4.7) (Adopted 02/10/2016)

4.15 Arizona Room (Accessory Room).

- A. A permit is required to build a (Arizona/Accessory Room) on a raised deck. The permit application must include a plan of the addition, elevations and details of the construction, description of the materials & colors. See 4.5, 4.6, 4.7, 4.15D & CC&R 3.27.
- B. A City of Mesa permit is required and you may pick up a Mesa packet in the office to fill out. A permit from Carriage Manor must be submitted with the city request.

- C. The highest point of the roof of an abutted Arizona Room must be on the side to which the room is abutted to the Park Model. The height of abutted Arizona Room will be the height of the adjacent sidewall of the Park Model to which it is being abutted. (See Exhibit B)
- D. Below is a list of requirements.
 - (1) Does not hinder or restrict the use of any exit from the principal unit.
 - (2) Prefab or "stick built" Accessory Room units are approved for Park Models and Manufactured Homes.
 - (3) Glass in doors or sliders are approved.
 - (4) Six inches (6) or less space between windows may be considered in the 33% required window glass space.
 - (5) Maximum area of 520 square feet (A total of 920 sq. ft. for Park Model & Accessory Room)
 - (6) Minimum UNOBSTRUCTED parking space shall be 9' x 20' and shall not be enclosed. (**Revised 01/14/2015**)
 - (7) Smoke alarm must be installed in the accessory room.
 - (8) Partitions may be used to accommodate laundry, bath, and toilet facilities.
 - (9) Walls may consist of conventional wood framing or modular (prefab) construction.
 - (10) Glass located within twenty-four inches (24") of a doorway or eighteen inches (18") of a floor must be tempered.
 - (11) At least thirty-three (33%) of the surface area of the front elevation must be open for glass.
 - (12) Insurance See 1.4
 - (13) Corner building must have 20% on the street side measured from the floor to 6'8" across the building. (**Revised 01/14/2015**)
 - (14) All stairs at the Accessory Room must meet city of Mesa code. (See 4.7) (**Adopted 02/10/2016**)
 - (15) Skirting to compliment Park Model color. (**Adopted 02/10/2016**)

4.16 Landscaping Guidelines.

- A. Landscape Requirement. Each lot must be landscaped in compliance with the Design Guidelines a detailed landscaping plan must be provided. See 3.32 CC&Rs Required Landscaping
- B. The "landscape" as described in this section refers to all those elements that give form to the exterior environment of the Carriage Manor Resort individual lots. These include such items as the variety and placement of plant material and inert ground cover.
- C. Water conservation is a priority when designing landscaping. Since recreational vehicles and manufactured homes within Carriage Manor Resort will be of varying types and sizes, landscaping, as a design element, will play the key role in creating and conveying the overall character of Carriage Manor Resort. The purpose of the landscaping guidelines is to provide design criteria to ensure that Carriage Manor Resort achieves an image that is distinctive, clearly understandable and unified, and in full compliance with the prevailing CC&R's.
- D. Specific materials and treatments are outlined in the following sub-

sections:

- (1) Dwarf species of plants are strongly recommended.
- (2) The ARC and BOD have approved Artificial Turf as front yard ground cover. It must be professionally installed and be covered by a manufacturer's warranty of at least eight years. A permit request must provide a box sample of the exact turf product at least one square foot in size along with the manufacturers' product specification. The product pile weight must range between 65-90 ounces per square foot, with a maximum width of stitched gage at $\frac{3}{4}$ inches & with backing of urethane (permeable) for drainage. It shall not exceed $2\frac{1}{4}$ inches. Turf must contain at least two shades of green (not including thatch). It must contain green or brown thatch. Only green turf colors are acceptable. Installation base must be on a sub base of compacted aggregate material $\frac{3}{8}$ minus granite. Infill material shall be according to turf manufacturers specification and industry standards with a minimum of two (2) pounds per square foot. All seams must be glued together and not nailed. The owner must keep the artificial turf maintained in a like new condition and color with no tears, visible seams, or exposed edges. The ARC & BOD reserve the rights to require the owner repair, reinstall, & remove any area of the turf that does not meet our requirements. **(Revised 06/17/2020)**
- (3) Each lot owner shall make a decision as to what accepted trees, shrubs, and general plantings are to be used for their landscaping design. "Jumping Cholla" cactus, Olive trees, Royal palms, Date palms, Australian Bottle trees, oleander and Bougainvillea are not approved. However, Pigmy (miniature) date palms not bearing fruit are allowed.
- (4) All organic landscape material should be indigenous to Arizona.
- (5) New plants and trees may not extend beyond the property lines or obscure reading of the electric meter from the street.
- (6) Areas of the lot which do not contain plants must have dust free gravel or rock at a minimum depth of $1\frac{1}{2}$ " to 2".
- (7) Minimum gravel size shall be $\frac{1}{2}$ " screened.
- (8) Plastic or Visqueen under gravel is not approved.
- (9) Barrier in front of lot to keep gravel from washing onto street.
- (10) Placing of all materials, organic or inorganic, within easement areas is permitted but should subsequent developments require removal, such removal shall be at the owners expense.
- (11) Board of Directors reserves its right to effect proper pruning, trimming, and general maintenance of all landscaping materials and improvements extending beyond property lines or causing jeopardy to other residents or vehicles after ten (10) days written notice.
- (12) Flag Poles. Are permitted to maximum height of Twenty (20) feet. Verify location of utilities with maintenance.
- (13) Only two trees are allowed per lot. (A saguaro cactus is not counted as a tree)
- (14) Plants and shrubs of the Southwest that don't require water are suggested.
- (15) A permit is not required for removal of trees or plants. **(Revised 01/14/2015)**

4.17 Trellises, Sunscreens and Privacy Screens (Revised 09/17/2025)

A. Trellises

1. Trellises shall be located only on the interior of the lot, not on the property line.
2. Trellises are not to be used ads property boundaries or exceed the height of the carport roof or the deck railing.
3. Trellises must be securely attached with metal fasteners. (no zip ties)
4. Trellises will be only of metal or vinyl composition.
5. PVC leaf trellises will not be allowed.
6. Trellises are of conventional design and color.
7. Perimeter lots at rear may be an exception – Subject to ARC Approval.

B. Sunscreens

1. Permanent sunscreens shall be metal framed with a sunscreen insert that shall be metal, vinyl, or mesh.
2. They shall extend downward from the awning and be securely anchored. (no zip ties)
3. Roll Up Sunscreens may be placed at the opening or side of the carport or deck and must be anchored securely at the bottom during use.
4. Sunscreens are only to be rolled down while in occupancy.
5. Sunscreens shall be removed or replaced if they become unsightly.
6. Tarps are not allowed.

C. Privacy Screens

Privacy screens and free-standing screens of any kind or material are not allowed anywhere on the deck or patio.

4.18 Drip System.

A. Drip systems shall be approved by the ARC to assist the owner in proper irrigation of their landscaping. Water line must be attached above gate valve.

B. Drip systems must not be attached to the "park tree" irrigation system.

C. As it may affect the safety, well-being and general benefit of all Carriage Manor Resort residents and the project, in general, the Board of Directors reserves the right to restrict or prohibit watering or other water uses, based on unpredictable or uncontrollable water shortages. ARC and/or Board of Directors cannot be held responsible for loss of organic landscape materials due to malfunction, or restrictions of water supply.

4.19 Lot Line Fences. Fences which do not exceed thirty-two (32) inches above the natural grade in height shall be allowed along the property lot lines. The location, type, and design must be approved by the ARC.

A. Fences are allowed to have a three-(3) to five-(5) foot gate that crosses the side five (5) feet easement to enclose the area behind the unit. Gate materials must be approved by ARC. (Revised 03/20/19)

B. Concrete block, stucco block, wrought iron with block or brick combinations and chain link are all approved fence materials. All other masonry materials are subject to approval. No exposed wood is allowed. Re-bar is required in walls and footing.

- C. Walls or fences in the front of the lot are not approved.
 - D. The front seven (7) feet on either side should be stepped down so as not to obstruct view of oncoming traffic. **(Revised 03/20/2019)**
- 4.20 Landscape Lighting. Lighting of the landscape is allowed for safety and design purposes. If lights are used, they will be low voltage and UL approved for outdoor use. Lights must be directed away from neighbors' properties. Location, size and type of lights will be approved by the ARC.
- 4.21 Barbecue.
- A. Open fire pits will not be allowed, however outdoor propane heaters are allowed. **(Revised 01/14/2015)**
 - B. All outdoor cooking equipment must be portable.
- 4.22 Pools, Hot Tubs. Swimming pools, kiddie pools, hot tubs or whirlpool spas are not approved on any lot. **(Revised 10/19/2025)**
- 4.23 Exemptions. (Grandfather Clause Defined)
- A. Park Model homes, awnings, storage sheds and Arizona Rooms erected before a design guideline change, and which are in compliance with the design guidelines as of the date of construction, shall be exempted from all future design guidelines changes unless mandated by local, state or federal agencies, except as follows:

Any improvement to a lot which was completed within the then existing restrictions is required to be brought into compliance with guidelines restrictions imposed at a later date if the improvement is being replaced, repaired, rebuilt or mandated by local, state or federal agencies.

DESIGN GUIDELINES

EXHIBIT "A-1"

RV PLACEMENT FOR MOTOR HOME FIFTH WHEEL & TRAILERS

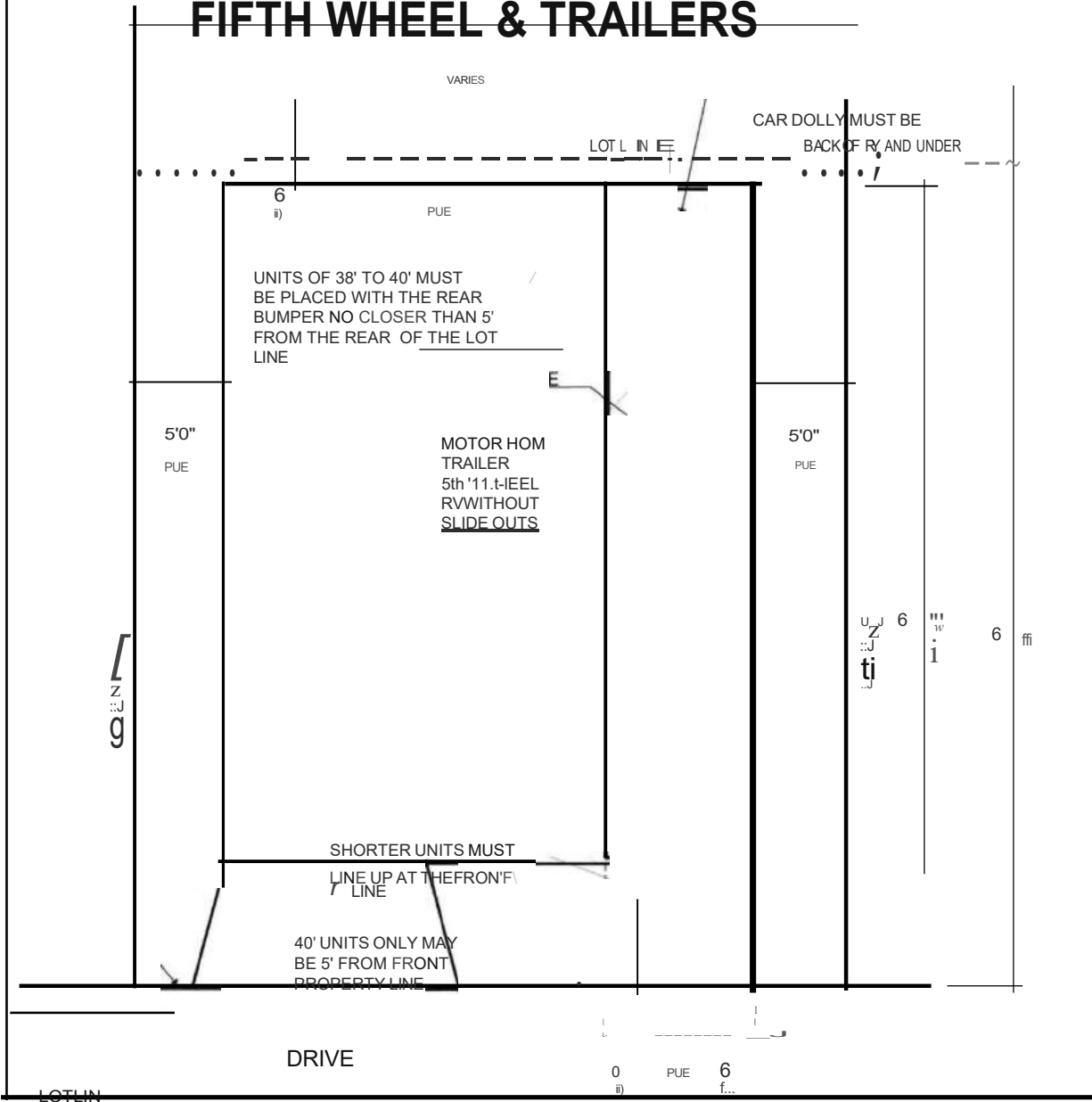

RIBBON CURB

STREET

LMCJA-10001

150310CADFILE

PUE: PUBLIC UTILITY EASEMENT

DESIGN GUIDELINES

EXHIBIT "A-2"

RV PLACEMENT FOR MOTOR HOME FIFTH WHEEL & TRAILERS

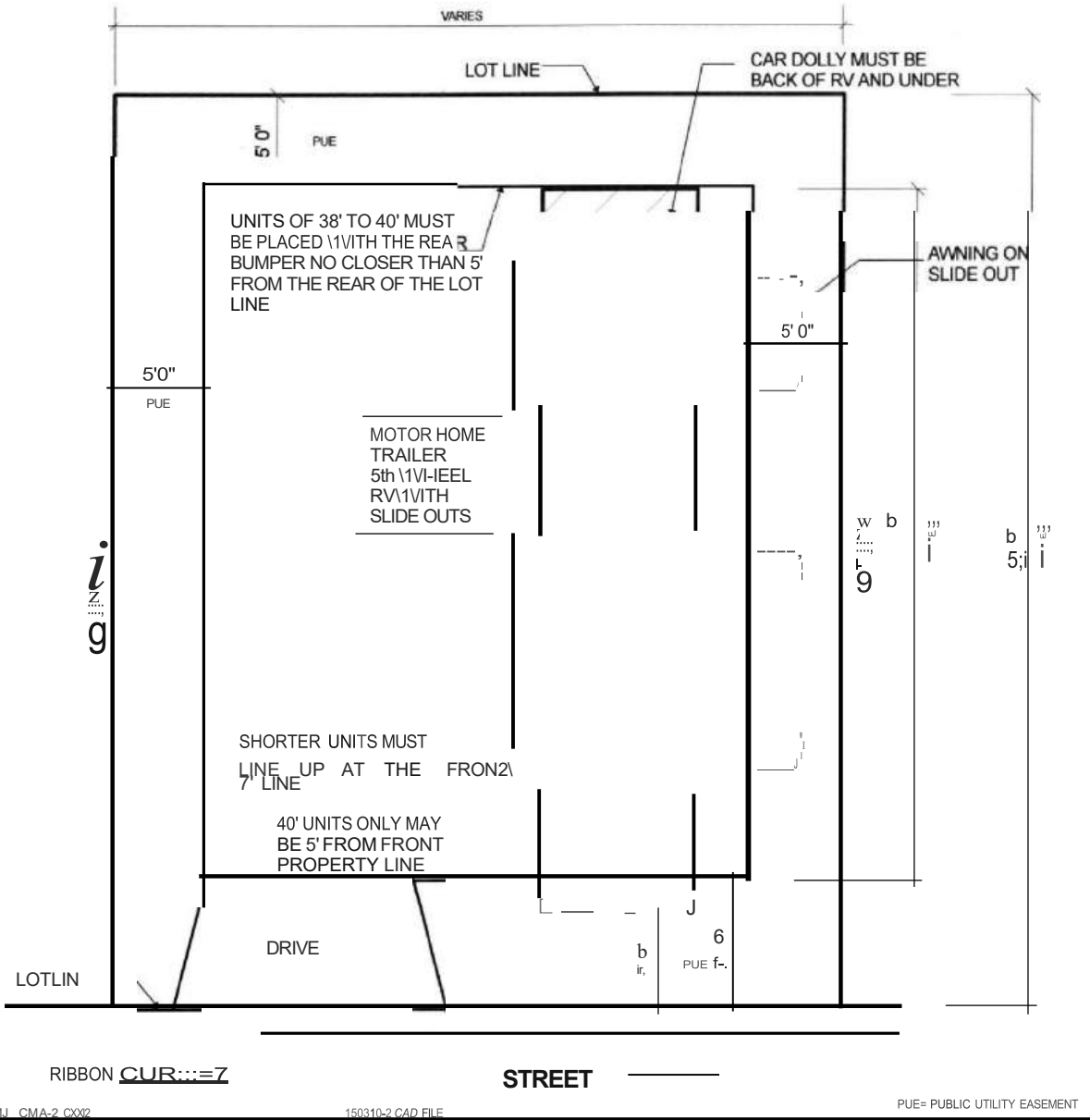

DESIGN GUIDELINES

EXHIBIT "B"

NOTE: DIMENSIONS WHERE SHOWN AT POINTS OF ELEVATIONS ARE MAXIMUM HEIGHTS!

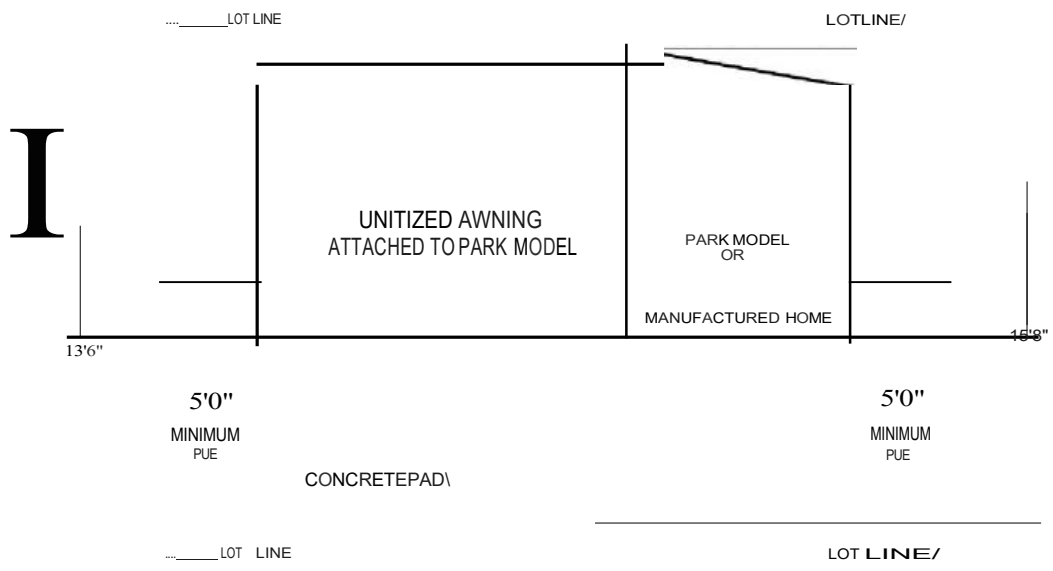
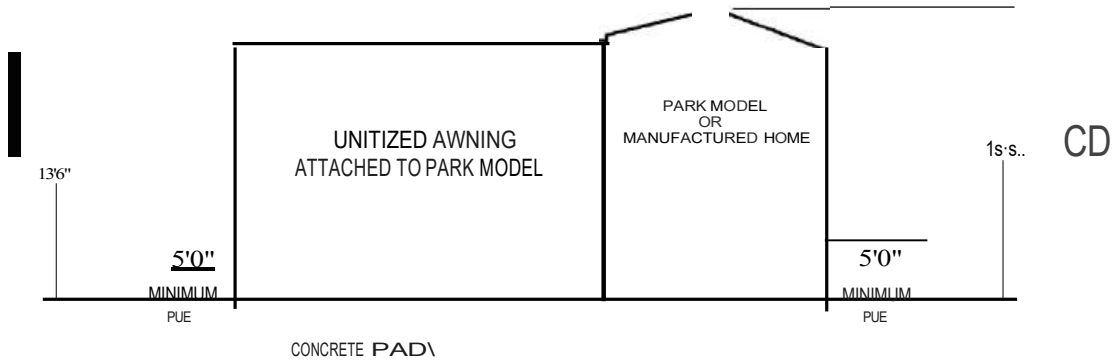

MAXIMUM HEIGHT OF AN AWNING SHALL NOT EXCEED 15'8". WHEN INSTALLED ON A PARK MODEL, THE PEAK OF THE AWNING MUST MEET THE EAVE OF THE PARK MODEL, AND MUST BE UNITIZED.

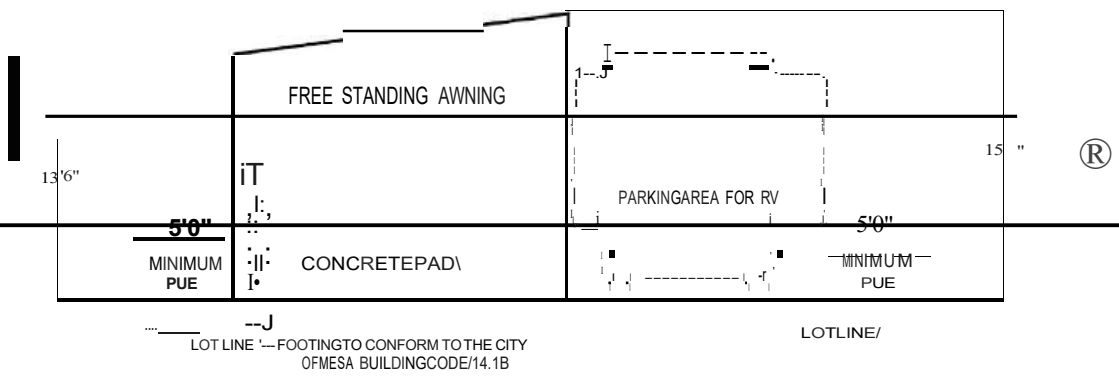

REDRAWN APR. 4, 2019 BY RNC TO SHOW MAXIMUM HEIGHT CHANGES

PUE= PUBLIC UTILITY EASEMENT

LEAVE THIS SHEET BLANK

CRITERIA FOR AMATEUR RADIO (HAM RADIO) INSTALLATIONS REQUIRING ELECTRONICS CLUB AND ARCHITECTURAL REVIEW COMMITTEE APPROVAL

The following criteria has been established to ensure compliance and integrity within the resort by way of remaining attentive to structural and electrical safety aspects as well as aesthetic values,

1. Applicant to be duly licensed and / or authorized under FCC regulations
2. All applications and installations shall be approved subject to withdrawal should circumstances warrant.
3. Should the number of applied-for- installations in the resort exceed (10) a complete re-evaluation of all installed antennas approved under this process shall be carried out.
4. Application may be made by owner and or parties with duly authorized authority for such application on the lot specified in the application.
5. Antennas shall be commercially built or compatible in appearance and serviceability. Installation of Amateur Radio Yagi antennas and or satellite dishes will not be allowed.
6. Antenna height is restricted to not more than 32 ft.
7. Supporting guy wires will not be allowed.
8. Base mounting masts and hardware shall be color coordinated so as to match the exterior trim of the Park Model RV
9. All installation shall have specifications that indicate installation will be able to withstand services in local wind conditions. (e.g. Butternut HV-6 designed to withstand winds in 80 mph without guying in the absence of ice.)
10. The base of the antenna shall be at DC ground potential to avoid any shock hazard.
11. Lightning protection shall be installed.
12. In the event of television interference to anyone within the resort, radio operations within the resort may be terminated until the problem is resolved.
13. Application for Architectural Antenna installations shall be submitted first to the Electronic Club to certify compliance, then to the Architectural Committee for final approval or disapproval.

DESIGN GUIDELINES

EXHIBIT "G"

DRAWING OF TYPICAL LOT SHOWING LOCATION OF CONSTRUCTION

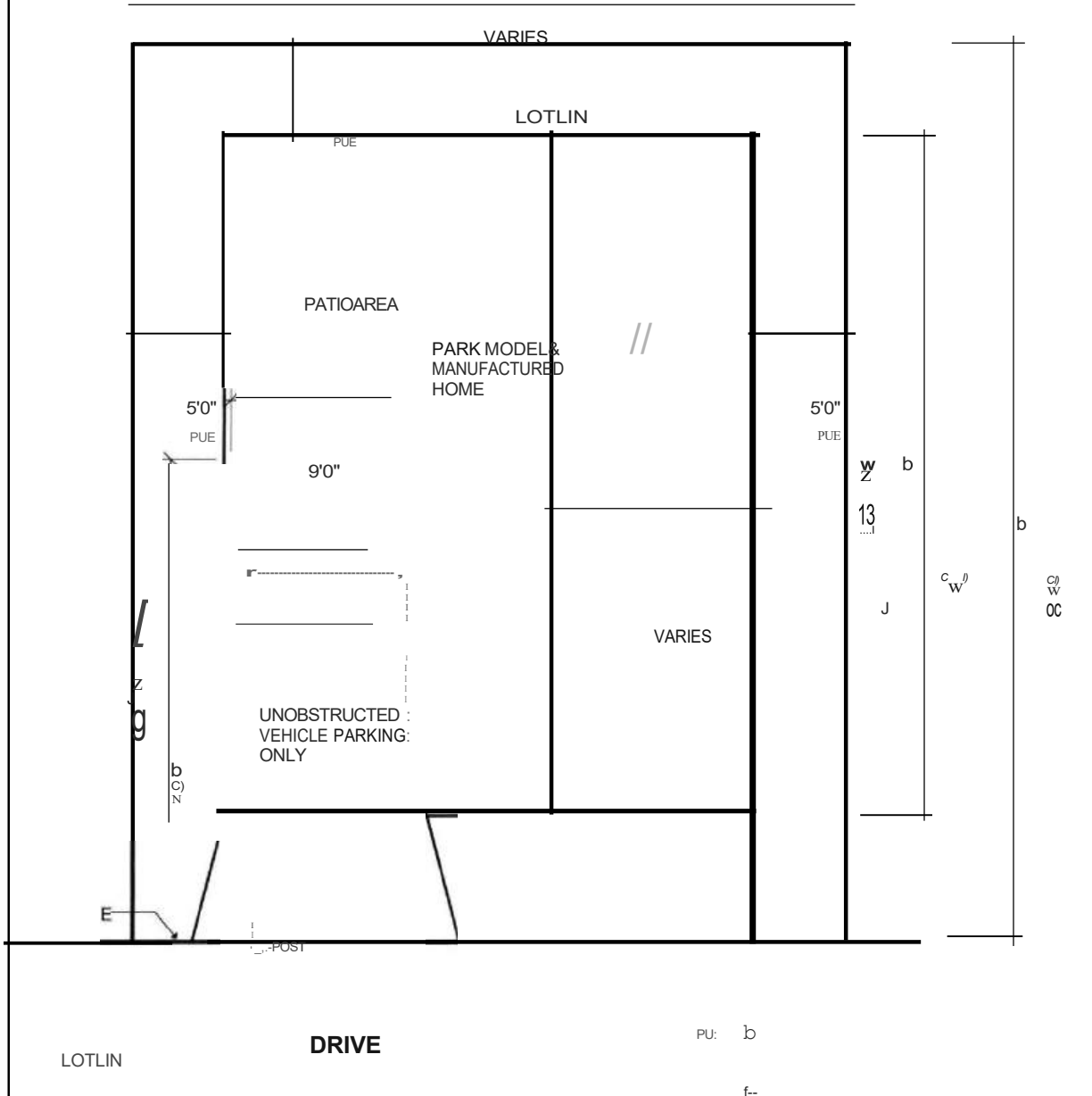

DESIGN GUIDELINES

EXHIBIT "H"

IMPROVEMENTS OR ADDITIONS TO AN OWNERS LOT WHICH MAY REQUIRE CITY OF MESA BUILDING PERMITS.

A. ELECTRIC

1. New Service to storage shed area (accessory room)
2. Service to new external appliance (Water Heater, Softener-AC-5w amp, etc.)
3. Service to Arizona Room (included on AZ / accessory room permit)
4. New pedestals.

B. PLUMBING

1. Service to storage shed or AZ room (accessory room)
2. Installation of external water treatment devices

C. DECKS (Required for heights over 30")

D. ANY STRUCTURE

1. RV Park Models
2. Manufactured Home
3. Awnings
4. Arizona Rooms (Accessory Room)
5. Alterations to any of above involving framing or support changes.
6. All storage structures (i.e. sheds, tool storage and / or work shop)
7. Decks with storage structures

It is always best to check with the City Building Department to determine whether or not a permit is required for your project.

CITY BUILDING DEPARTMENT
55 CENTER STREET
P.O. BOX 1466
MESA AZ 85211-1466
4806444273
FAX 480 644 2418

MJ CM H0008

DESIGN GUIDELINES

EXHIBIT "I"

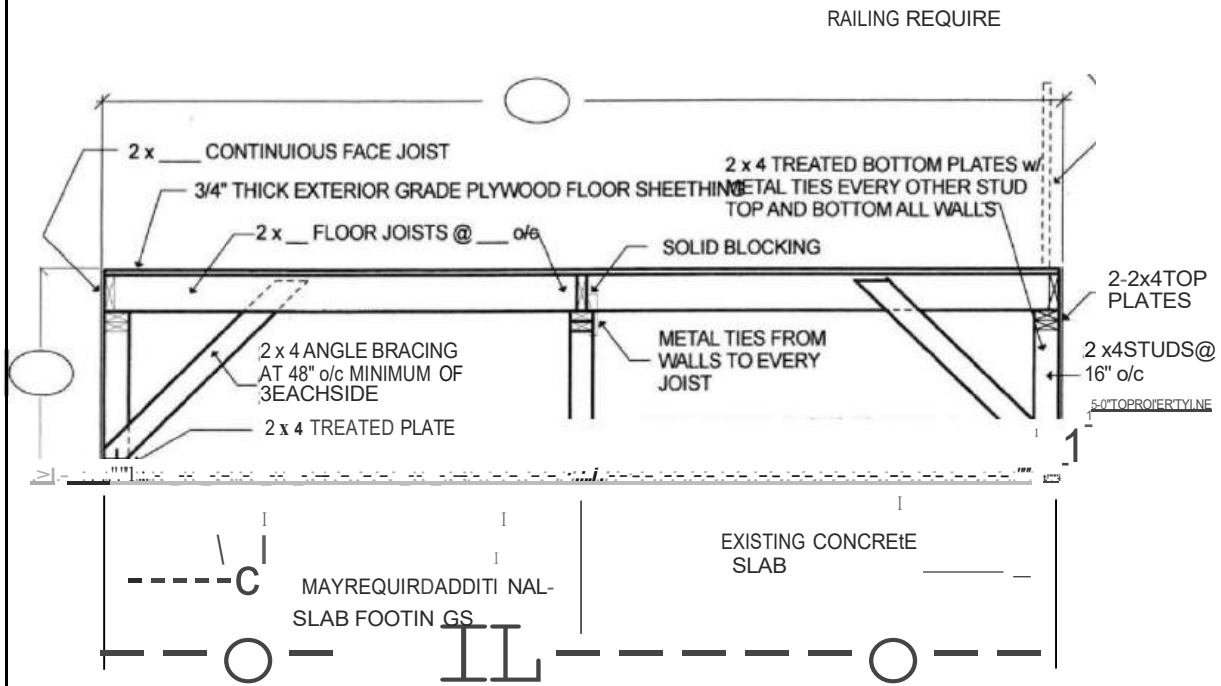

- SHOW DIMENSIONS REPRESENTED BY CIRCLES
- * ALL METAL CONNECTORS MUST BE ICBO APPROVED
- * PROVIDE UNDER FLOOR ACCESS AND VENTILATION PER UBC SEC. 2317.3 & 2317.7

THESE ARE MINIMUM RECOMMENDED REQUIRMENTS FOR BUILDING A DECK IN CARRIAGE MANOR

- 1 PROVIDE ALL MEASUREMENTS REPRESENTED BY CIRCLES AND BLANKS
 - 2 FOR 2x6 FLOOR JOIST THE **MINIMUM** REQUIREMENTS FOR SPAN ARE AS FOLLOVS.
 - 2x6@12"oc= 10'9"
 - 2x6@16"oc= 9'9"
 - 2x6@19.2"oc= 9'1"
 - 2x6@24"oc= 8'1"
- AT LEAST 3 2x4 CROSS BRACES ARE REQUIRED

..NQ!f:

CITY OF MESA PERMIT IS REQUIRED OVER 30". HOWEVER, THE ABOVE IS REQUIRED IF YOU INTEND TO ADD AN ARIZONA ROOM IN THE FUTURE.

THESE ARE CITY OF MESA REQUIREMENTS AS OF THIS PRINTING

LMJ CM 1 00J9R

150310-9CAO FILE

EXHIBIT "J"

BUILDINGS INCLUDING ROOF OVERHANG
CANNOT INCREASE INTO OPEN AREA
FROM WALL REQUIRED DISTANCE TO BE
CONFIRMED v.,m SRP

SRP EQUIPMENT WILL VARY IN SIZE
& SHAPE. THE OWNER MUST CHECK
SRP TO ESTABLISH REQUIREMENTS

EIGHT INCH MASONRY
WALL AT HEIGHT AS
REQUIRED BY SRP.

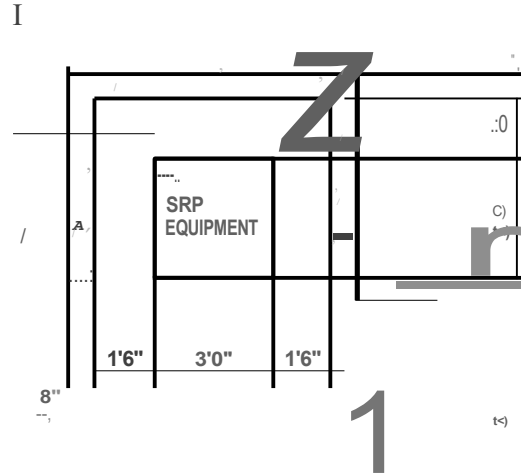

THIS INFORMATION SHEET IS TO INFORM OWNERS WITH
SRP TRANSFORMERS ON THERE LOT OR AJOINING LOT
THAT THEYMUST VERIFY WITH SRP BEFORE DOING
AND PLANNING OR CONSTRUCTION

CHECK LIST FOR MANUFACTURED HOME AND PARK MODEL PERMIT APPLICATION

- PERMIT REQUEST FROM APPLICANT
- PERMIT FEE (\$100.00)
- NAME OF DEALER & CONTRACTOR/ INSTALLER
- MANUFACTURER SPECIFICATION SHEET (IF STANDARD SHEET ID PROVIDED CROSS OFF ITEMS NOT PROVIDED IN THIS PROJECT)
- PLOT PLAN
- ESTIMATED START DATE
- FLOOR PLAN
- BUILDING ELEVATIONS (4) SIDES
- AVVNING SUPPLIER
- DECK AND STEPS. PROVIDE PLAN AND SECTION WTH MATERIAL NOTED (SEE EXHIBIT "I")
- SHED (ACCESSORY BUILDING) IF PROVIDED PLAN SECTION WTH MATERIAL NOTED (SEE EXHIBIT "I")
- INDICATE SKIRTING MATERIAL AND THAT A CONCRETE RIBBON IS BEING PROVIDED
- IF A SRP TRANSFORMER IS ON THE LOT PROVIDE EVIDANCE OF CONTACT WTH SRP AND PROJECT LOCATION MEETS THEIR REQUIRMENTS
- NO EXPOSED MJOD

SEE DESIGN GUIDELINES FOR INFORMATION REQUIRED. (PERMIT REQUEST 2.1, SUBMISSIN SEQUENCE 2.2, TIME LIMITS 3.1, SETBACKS 4.2, ROOFING 4.4, SIDING4.5, SKIRTING 4.6, PARKMODEL4.9, MANUFACTURED HOME4.10.

CARRIAGE MANOR RV RESORT ASSOCIATION, INC.
RULES AND REGULATIONS

PART 1
Definitions

- 1.1 Resident. An owner or adult renter who resides in a residence vehicle on a designated lot. Limited to two (2) adults per residence vehicle without written approval of the Board of Directors (Children will not be counted in the complement).
- 1.2 Owner. The legally recorded owner of a lot.
- 1.3 Guest. An adult who resides with a resident or in a unit with permission of that unit's Owner; no rent may be charged. Each guest is limited to a period not to exceed two (2) weeks per calendar year. Guests are limited to two (2) adults per residence. Children are considered guests but will not be counted in the complement. All guests shall be registered at the Main Desk. (Revised 6/17/2020)
- 1.4 Non-Member Resident. An age-qualified person living in a unit with an owner, who does not hold title to the lot. (Adopted 10/19/2022)
- 1.5 Renter. Any non-owner, tenant, or free-occupier who is residing on a lot with the owner's permission, and by written third-party agreement. One renter must be age 55+ and the other must be 40+. Two renters are allowed per lot. (Adopted 10/19/2022)
- 1.6 Child/Children. Persons under eighteen (18) years of age.
- A. Visitor. A Person who visits a resident of the Resort but does not stay overnight.
- 1.7 Age.
- A. Adults fifty-five (55) years of age and older under the Federal Fair Housing Amendments Act of September, 1988;
- B. Proof of age upon purchase or rental of a lot will be required;
- C. One (1) resident in each household must have passed their fifty-fifth (55th) birthday at the time of occupancy unless written approval of the board of Directors has been granted;
- D. All residents of the household must have passed their fortieth (40th) birthday; and
- E. No children may reside in the resort as a resident.
- 1.8 Residence Vehicles. (Revised 6/17/2020)
- A. Park Model. (See CC&R's 1.14)
- B. Recreational Vehicle. (See CC&R's 1.17)
- C. Manufactured Home. (See CC&R's 1.17)

- 1.9 Common Areas. Includes streets, sidewalks, recreation areas and the building complex. Please remember that the Common Area facilities are for the use of the residents. Although guests and visitors are extended the privilege to use them, this is subject to revocation if abused.

PART 2
Decorum

- 2.1 Quiet Hours. Quiet hours are from 11:00 PM to 7:00 AM.
- 2.2 Common Areas. Residents, guests and visitors are expected to maintain the Common Area facilities in a clean and orderly manner.
- 2.3 Smoking. Smoking is not permitted in any Resort building.
- 2.4 Attire. Proper attire is required, e.g., shirts and shoes, etc. while in all Resort buildings.
- 2.5 Vehicles on Sidewalks. Bicycles, golf carts, roller skates, roller blades, skate boards and other vehicles are prohibited from being driven or operated on sidewalks, with the exception of Handi-cap golf carts on the sidewalk to the Pickleball courts. (Revised 01/14/2015)
- 2.6 Children. CHILDREN SHALL BE ACCOMPANIED AND SUPERVISED BY AN ADULT RESIDENT, GUEST OR VISITOR WHEN IN THE COMMON AREAS.

PART 3
General Information

- 3.1 Guest Registration. Residents and guests, including their children, must register at the Main Desk or with Security upon first arrival.
- 3.2 Extended Absences. Residents shall notify the Main Desk upon leaving the Resort for five (5) days or longer and as soon as possible upon return to ensure proper accurate records.
- 3.3 Messages. Emergency telephone messages will be delivered. All other messages will be posted on the Message Board.
- 3.4 Mail. Mail is delivered by the U. S. Postal Service in the mail lock boxes at the Resort Mail Room. The lot number must be on all mail. Do not call the Main Desk to inquire if the mail has arrived.
- 3.5 Posted Rules. Specific rules are posted in the swimming/Jacuzzi area, other recreational areas and the laundry room.

- 3.6 Solicitation. Excluding Resort activities, door to-door sales or soliciting funds is prohibited.
- 3.7 Emergencies. Dial 9-1-1 and notify Security (986-2467) for all fire and medical emergencies.

PART 4 **Residence Vehicles**

- 4.1 Approval. All residence vehicles must be approved before being placed in the Resort. All residence vehicles are subject to inspection and are accepted on the basis of age and appearance. Residence vehicles over ten (10) years of age will not be accepted unless approved by the Board of Directors. Only one resident vehicle per lot is permitted unless otherwise approved. Contact the Main Desk for permit forms and additional information. (Revised 06/16/2021)
- 4.2 Recreational Vehicles. A Recreational Vehicle used as a residence shall be self-contained and equipped with an approved sewer trap and vent and meet all Federal, State, County and City requirements and RV codes. (Revised 06/16/2021)
- 4.3 Skirting. Skirting, this is required for all Park Models and RV's which remain in the Resort on an annual basis, shall be limited to an approved, conventional type, color and design which blends in with the vehicle.
- 4.4 Prohibited Vehicles. Vehicles not permitted as a residence include:
- A. Mobile homes;
 - B. Tents, tent trailers and vans;
 - C. Converted school buses or trucks;
 - D. Truck-mounted campers;
 - E. Under 26' can park on the lot but cannot be occupied.
 - F. Any other vehicle which, in the opinion of the Architectural Review Committee or Board of Directors detracts from the intent, purpose or general appearance of the Resort. (Revised 06/16/2021)
- 4.5 Placement. The residence vehicle must be backed onto the lot with the "curb" side doorways facing the patio. Proper placement requires a setback of seven (7) feet from any portion of the residence vehicle other than the trailer tongue to the front of the lot line and a minimum setback of five (5) feet from any portion of the residence vehicle or awning to either side or to the rear of the lot line unless approved by the Board of Directors. If there are any questions about proper placement, contact the Main Desk or Security before completing the project. (SEE EXHIBIT "A" ATTACHED)

- 4.6 Hook-Ups. All hook-ups shall be properly made to the receptacles provided on each lot in accordance with the City of Mesa building codes or manufacturer's specifications.
- 4.7 Prohibited Lines and Ropes. Connecting of lines, clothes lines, wires or ropes between vehicles, water risers, electrical pedestals, trees, landscape items or vent pipes is prohibited.
- 4.8 Wheel Covers. Wheel covers used on residence vehicles must be constructed of materials suitable for this purpose. The use of cardboard, pieces of wood, Styrofoam, etc., is prohibited.
- 4.9 Recreational Vehicle. Shall mean a vehicle with or without its own mode of power designed to provide **temporary living quarters** for recreational camping or travel (i.e.: camping trailers, fifth wheels, and Motor Homes)

Class B, B+ Motor Homes and other Motor Homes, trailers and 5th wheels less than 26' do not qualify as **temporary living quarters** for the purpose of document. (Revised 06/16/2021)

PART 5

Transportation Vehicles and Parking

- 5.1 Passenger Cars. No more than one (1) Recreational Vehicle or Park Model. Up to two (2) pick-up trucks or passenger cars (including passenger van seating less than nine (9) Passengers) shall be parked or maintained on any Lot. No more than one (1) motorcycle or one (1) golf cart. In place of two (2) passenger vehicles: i.e., (one) 1 passenger vehicle plus two (2) golf carts OR two (2) motorcycles; OR one (1) golf cart and one (1) motorcycle shall be parked or maintained on any Lot. No passenger cars or trucks may be parked or maintained on the setback area across the front seven (7) feet of the Lot. Furthermore, maintaining more than three (3) vehicles on any lot shall be prohibited. (Revised 08/25/2021)
- 5.2 Designated Parking. Any vehicle not parked appropriately on a residence lot must be properly parked in a designated parking area and display a permit as defined in Part 5.5. (Revised 01/17/2007)
- 5.3 Visitor Parking. On street parking is authorized on the street side opposite the fire lanes between the hours of 7:00 AM and midnight.
- 5.4 Prohibited Vehicles. Vehicles prohibited from being parked or stored on any lot or street include:
- A. Cargo, utility and golf cart trailers;
 - B. Boats and boat trailers;
 - C. Any other vehicle not expressly designed for RV residence or transportation;

- D. Any vehicle which detracts from the intent, purpose or general appearance of the Resort, or
- E. Car dollies, unless stored under the rear of the recreational vehicle.

5.5 Special Use Parking Permits. Special Use Parking Permits Special Use Parking Permits (Permits for spots 1-21) are obtained from the Security office and are subject to the following rules:

- A. Permits are available for 10 days per month, per lot, on a year-round basis for all vehicles. Vehicles must be registered in the office.
- B. Permits will be assigned a space number by the Security office.
- C. Permit parking from 4:00 PM – 7:00 AM at North side of Tennis Courts. Non permitted vehicles must vacate spaces by 4:00 PM.
- D. Parking spaces 1 thru 12 will be available for cars, pickups and vans.
- E. Parking spaces 13 thru 18 will be available for trailers and overflow cars.
- F. Parking spaces 19 thru 21 will be available for motorhomes, fifth wheel trailers and trucks. (Large Vehicles Only)
- G. Exception requests for guests staying the maximum of 14 days may be approved by Security or a designated approver and/or General Manager.
- H. Additional specific Special Use Parking Permit rules:
 - Vehicles must be backed into parking space
 - No Parallel Parking
 - Trailers and fifth wheels must be unhitched from tow vehicle
 - Tow vehicle and towed vehicle must both exhibit a Permit
 - Tow Dollies, whether or not supporting other vehicles, shall be unhitched from tow vehicles and shall be stored as close as possible to the rear of tow vehicle
 - Tow Dollies supporting another vehicle or left alone shall require a separate Permit.
 - Vehicles cannot be occupied overnight
 - Vehicles cannot be hooked up to any outside utilities or facilities • Generators/alternators cannot be used
 - Leveling jacks cannot be used.

(Revised 11/20/24)

5.6 Patriot's Park Parking

- A. Shall be used for short term parking only.
- B. Vehicles limited to a maximum of 21 ft.

5.7 Wheel Covers. Wheel covers used on transportation vehicles must be constructed of materials suitable for this purpose. The use of cardboard, pieces of wood, styro-foam, etc., is prohibited.

- 5.8 Bicycles. Bicycles in the common areas shall be parked in the bicycle parking racks when provided and available.

PART 6 **Vehicles and Traffic**

The provisions of **PART 6 Traffic Control** shall refer exclusively to the operation of motor vehicles and vehicles upon the Common Area Streets of Carriage Manor RV Resort Association, Inc. (“Association”) only.

6.1 Definitions.

- A. Driver: A person who drives, operates or is in actual control of a motor vehicle or vehicle, as defined in the Definitions.
- B. Intersection: The interior area within marked lines or imaginary lines connecting the corners of adjoining streets.
- C. Pedestrian: A person traveling or moving on foot, with or without aid of a non-powered assist apparatus, cane or crutches.
- D. Motor Vehicle: Any vehicle powered by a gas or diesel engine or an electric, or any combination thereof.
- E. Stop: A complete cessation of movement.
- F. Street: Any street or thoroughfare, including the Common Area parking areas.
- G. Vehicle: Any unit or device with wheels attached which allow it to be pushed, pulled, towed, or propelled and controlled by human power. Including but not limited to: a unicycle, a bicycle with two or more wheels, a skateboard, roller blades, roller skates or other like contrivances. The term Vehicle does not include non-motorized wheelchairs used by disabled residents for ambulation.
- H. Traffic: Motor vehicles, vehicles, and pedestrians.

6.2 Privilege To Operate.

- A. A driver, legally licensed in his/her home state, may drive a motor vehicle on the streets of the Association Common Areas.
- B. A golf cart shall only be driven by an adult or licensed driver.

6.3 Careless Driving. A person shall not drive, operate, or control a motor vehicle or a vehicle in a manner so as to disregard the safety and welfare of others or the property of others.

6.4 Owner Permitting Illegal Operation. An owner shall not knowingly permit another person to drive, operate or control his/her motor vehicle or vehicle illegally.

6.5 Parking.

- A. A driver shall not park nor leave unattended a motor vehicle or vehicle on the side of the street designated by sign as a Fire Lane

- placed in accordance with Mesa City Code.
- B. A driver shall not park nor leave unattended a motor vehicle or a vehicle in a parking area specifically designated by sign for a particular type of vehicle or an allowed time.
- 6.6 Speed Limit. A driver of a motor vehicle or vehicle shall not exceed a speed of ten (10) miles per hour.
- 6.7 Stop.
- A. A driver of a motor vehicle or vehicle shall stop before entering an intersection controlled by, and when facing a STOP SIGN. After stopping, the driver shall yield the right of way to any other motor vehicle, vehicle or pedestrian which is so close as to constitute an immediate hazard.
- B. EXCEPTION: A bicycle driver shall stop at all intersections when traffic is present in the immediate vicinity. If the area is clear of traffic, a bicycle driver must slow down, and look carefully in all directions before traveling through the intersection at a slow pace, under 5 MPH.
- 6.8 Vehicle Lighting. A motor vehicle or vehicle operated on the streets at times of dusk to dawn shall display one or more white lights to the front and one or more red lights to the rear.
- 6.9 Yield Right of Way. A driver of a motor vehicle or vehicle shall yield the right of way to any pedestrian, or any other motor vehicle or vehicle, which is so close as to constitute an immediate hazard.
- 6.10 Repairs. Repairing motor vehicles or vehicles on lots, private streets or Common Areas is prohibited. A repair service or tow truck may be called to move your disabled motor vehicle to a place of repair, but repairs shall not be made on site.
- 6.11 Vehicle Registration. All resident motor vehicles shall be registered at the main desk and display an entrance decal or proper permit at all times.
- 6.12 RV Storage. The resort does not provide storage facilities for RV's or other vehicles. If a need arises to bring such a vehicle into the Resort, a permit secured from the management or Security shall be properly displayed and clearly visible while the vehicle is parked.
- 6.13 Voluntary Compliance. Traffic laws across the United States and Canada require pedestrians to move upon the left side of a public street or highway, facing traffic, while striving to be visible during hours of darkness, and all motor vehicles and vehicles to operate upon the right

side of a public street or highway, exhibiting signals for stopping, changing lanes, turning left or right, etc. Therefore, it is incumbent upon all employees, residents, guests and visitors of this Resort to act responsibly, follow the spirit of these laws when within the Association Common Areas and use caution and common sense while moving on foot or operating any mode of transportation. We request your VOLUNTARY COMPLIANCE.

- 6.14 Enforcement And Adjudication. Enforcement and adjudication procedures for PART 6 VEHICLES AND TRAFFIC CONTROL are listed in PART 15 Enforcement; (pp 45 - 48) of the RULES AND REGULATIONS FOR CARRIAGE MANOR RV RESORT. (Revised 01/17/07)

PART 7 **Name Badge**

- 7.1 Name Badges Provided. A name badge is provided to:
A. All owners, and
B. Each rental resident or overnight guest, including their children, upon payment of a fee at the Main Desk. (Revised 03/11/2015)
- 7.2 Name Badge Wearing. Name badges are a means of introduction and identification. They shall be worn at all times when in the Common Areas other than the swimming/jacuzzi area, but should then be readily available.

PART 8 **Architectural Modification Permits**

- 8.1 External Changes. Contact the Main Desk before making a changes or additions to your lot or outside residence. Any permanent modification to a lot (structural or landscaping) must have prior written approval from the Architectural Review Committee ("ARC") before beginning the project.
- 8.2 Applications. Applications for permits may be secured at the Main Desk. Do not expect immediate approval; it may take several days. Approval is based on current requirements and is not subject to any prior conditions that may have existed in the Resort that no longer apply with present regulations. Any delivery made or any project begun without authorization is subject to being returned or removed at the owner's expense.
- 8.2.1 City Permits. The City of Mesa requires permits for placing Park Models, building "Arizona Rooms", storage buildings, and other construction programs. It is the lot owners responsibility to obtain these permits and required inspections.

- 8.3 Prior Approval. A detailed, approved permit signed by the ARC must be in possession before:
- A. Delivery of a park model;
 - B. Delivery or construction of a shed or storage building;
 - C. Modification to or on your lot;
 - D. Addition to any structure on your lot;
 - E. Commencing to construct or modify any fence or landscaping; or
 - F. Making any modifications or repairs to the exterior of any residence vehicle.
 - G. Making application to the City of Mesa for building permits.
Refer to Architectural Guidelines for additional information.
- 8.4 Dust Control. When residents or outside contractors are performing masonry, construction, and landscaping activity, steps must be taken to suppress any excessive dust by utilizing adequate dust control methods. A wet saw must be used when a construction project requires repetitive/continuous cutting of hard material such as, but not limited to, pavers, tile or masonry. (Adopted 02/14/2018)

PART 9

Setbacks and Easements

- 9.1 Setbacks. A setback of five (5) feet along the sides and rear, and seven (7) feet from the front of each lot is required.
- 9.2 Prohibited Uses. It is prohibited on a setback to:
- A. Place a park model or an extension of it on or over the setback;
 - B. Pour any concrete or asphalt;
 - C. Excavate, except for landscaping, more than one (1) foot in depth;
 - D. Lay bricks or paving stones on other than dry ground or sand;
 - E. No permanent or temporary structures or improvements may encroach that area, other than landscaping, approved fence gates (See Design Guidelines 4.19), and vehicles like golf carts, and motorcycles. Passenger Cars/Trucks are prohibited. (AC units, & movable steps and prefab storage sheds (See Design Guidelines 4.13.1) are allowed in the rear setback area. See 4.11-B)
(CC&R 3.27 & 4.2)
- 9.3 Damages. Any damages to utilities, utility facilities or connections caused by a resident, guest or visitor shall be the financial responsibility of the owner.
- 9.4 Removal. Any item placed on or over a setback that must be removed shall be done at the owner's expense.

PART 10
Animals

- 10.1 Introduction. Pursuant to Section 3.23 of the Carriage Manor RV Resort Declaration, the Board of Directors has adopted the following animal rules. The Board of Directors is expressly authorized to promulgate rules and regulations that further restrict the keeping of animals on the resort property. The cooperation of the Carriage Manor RV Resort Owners, Lessees, and Guests is important to help keep the resort property safe and to preserve the peace, quiet, and cleanliness of the resort property.
- 10.2 Definitions.
- A. Household animals includes companion animals such as domesticated cats, dogs, birds, or fish. It excludes “service,” “assistance,” or “feral” animals.
 - B. Assistance or service animals are those that perform tasks in accordance with provisions of the Federal Fair Housing Act and the Arizona Fair Housing Act.
 - C. Feral animals live wild but are descended from domesticated animals.
 - D. Aggressive animals are those credibly reported as aggressive or vicious.
 - E. Nuisance animals are those credibly reported as nuisances to other owners, lessees, or guests through behavior including, but not limited to, uncontrolled barking or roaming off the owner's or lessee's property.
 - F. Patriot's Park is the land located in the water retention basin in the southwest corner of the resort property. Dog park is the fenced-in section of Patriot's Park intended as an amenity to dog owners.
- 10.3 Animal numbers. Owners and lessees can own up to two dogs or cats.
- 10.4 Registration. All animals must be registered at the Main Desk upon acquisition and re-registered annually. Proof of current rabies inoculation shall be required pursuant to City of Mesa ordinance section 6-4-5; a current license is considered proof.
- 10.5 Animals at Large. Animals are never allowed to roam at large on the resort property. All dogs must be kept on a leash of six (6) feet or less when on the resort property, except for inside a Recreational Vehicle, park model, a fenced yard, or the fenced dog park. All dogs must be transported to and from the dog park or Patriot's Park.
- 10.6 Common areas. Household animals are not allowed in the Common areas. Registered assistance or service animals are excluded from this restriction.
- 10.7 Waste. All animal waste left must be immediately removed from all properties within the resort and disposed of in a sanitary fashion.

- 10.8 Dog Park and Patriot's Park regulations.
- A. Registration. All dogs must be registered pursuant to Rules and Regulations section 10.4 before park entrance.
 - B. Injury. Any injury to persons or property by a dog in the parks shall be the full responsibility of the dog owner or persons responsible for the dog when such damages are inflicted.
 - C. Aggression. In either Patriot's Park or the dog park, dogs with a bite history are not allowed. Dogs must be immediately removed by the owner at any sign of aggression.
 - D. Handlers. No more than two (2) dogs are permitted per handler in the parks.
 - E. Waste. All waste must be immediately picked up and disposed of sanitarily.
 - F. Patriot's Park Leashing. Dogs must be leashed and under handler control at all times in Patriot's Park (outside the fenced-in Dog Park area)
 - G. Dog Park Leashing. Dogs must be leashed and under handler control when entering or exiting the Dog Park. Within the fence they must be under voice control of their handler, who must remain in the enclosure with the dog at all times.

10.9 Animal Prohibitions.

- A. Wildlife. Deliberate feeding of wildlife is prohibited with the exception of bird feeders unless they create a nuisance.
- B. Feral animals. No owner, lessee, or guest shall do anything to attract, maintain, or increase the number of feral animals on the resort property.
- C. Commerce. Pursuant to C. C. & R's 3.23, animals cannot be kept, bred, or maintained for any commercial purpose.

- 10.10 Penalties. The Resort shall also have the right, but not the obligation, to enforce these Animal Rules pursuant to Part 12 of the Declaration, including any proceeding at law or in equity, not limited to an injunction requiring the removal of animals such as aggressive animals, nuisance animals, or others from the resort property. The prevailing party shall be entitled to recover reasonable attorney's fees, costs, and other expenses.

The Resort shall further have the right, but not the obligation, to enforce these Animal Rules through the assessment of fines in accordance with Paragraph 15.2 of the Rules and Regulations.

PART 11
Swimming Pool Area Rules

- 11.1 Residents and Guests Responsibilities. Only residents, guests and visitors shall be allowed in the pool area. Residents are responsible for their guests, visitors and their children at all times.
- 11.2 Name Badges. Name badges must be in possession.
- 11.3 Showers. Showers are required before entering the pool.
- 11.4 Lotions. The use of sunscreen lotions, creams or oil, etc., is prohibited in the pool or jacuzzi.
- 11.5 Running. There shall be no running, jumping or diving allowed in the pool area.
- 11.6 Glass Containers. Glass containers are strictly prohibited in the pool area.
- 11.7 Pets. Pets are prohibited in the pool area.
- 11.8 Children. Only children who are toilet trained or clad in certified swim diapers, as verified by the manufacturer, will be allowed in the pool. Children must be closely supervised by an adult resident, guest, or visitor at all times. Children are allowed to use the pool or be in the pool area from 10:00 AM to 6:00 PM daily, unless a water volleyball game is in progress between the hours of 12:00 to 2:00, at which time all children must leave the pool. Children under the age of 18 may play water volleyball if invited to or accompanied by an adult player. (Revised 02/19/2020)
- 11.9 Swim Wear. Appropriate swim wear is required. Absolutely no "cut-offs" are allowed.
- 11.10 Jacuzzi. Only adults are allowed in the jacuzzi.
- 11.11 Smoking. Smoking or the use of any other tobacco product in the pool area is prohibited.
- 11.12 Radios. Personal radios are allowed only when using earphones.
- 11.13 Items For Use In Pool.
- A. Approved items: Items allowing the pool user to float upright such as pool noodles, fabric attached to pool noodles to create a chair, pool saddles and pool hammocks (in seated position only). All the items used as a floatation device should take up no more space than the person using them. (Revised 11/20/2019)

- B. Prohibited items: Inflatable rafts, inflatable inner tubes and chairs. No toys that can hit another person such as (but not limited to) balls, frisbees, squirt guns, squishys and other toys. The exclusion to this is the volleyball in use during water volleyball hours.

To prevent damage to the filters, no small items are allowed (i.e. bobby pins, hair rollers, hair picks, etc.) (Revised 11/20/2019)

PART 12 **Miscellaneous**

- 12.1 Lot Numbers. All Lots must have a Lot number clearly visible from the street. (Revised 12/15/2021)
- 12.2 Antennas. Antennas may not extend more than four (4) feet above the roof line of the residence vehicle. Radio/TV interference emitted from the antenna is prohibited. Any variances shall be approved in writing by the ARC.
- 12.3 Business. No one may operate a business from within the Resort that attracts patrons from outside the Resort. Persons operating a business within the Resort are responsible for any and all city or state certifications, licenses, or permits to conduct that business. No advertising signs are allowed on any properties. (A business is defined as any transaction where one person receives a fee or gratuity from another for goods or services rendered.) (Revised 12/12/07)
- 12.4 Lot Maintenance. Maintenance of lots are the responsibility of each owner. Unkempt or unsightly lots shall be attended to by Resort employees when it becomes necessary with a fee assessed to the owner.
- 12.5 Patio and Deck Use. Patios and decks can be furnished with items designed for outdoor living, such as those described by stores as “patio”, “garden” or “outdoor”, and made of long-lasting weather-resistant materials such as plastic, metal, wicker, or hybrids. Small portable electric refrigerators are acceptable. (Revised 06/17/2020)
- 12.6 Private Property. Please respect your neighbor's right to privacy by using the streets rather than crossing through a private lot. This includes using a bicycle or when walking.
- 12.7 Patio Storage. Patios and the un-skirted space under the residence vehicle is not to be used for storage as this detracts from the appearance of the Resort.
- 12.8 Offensive Activity. No offensive activity shall be carried on within the Resort.

- 12.9 Signs. Without written approval from the Board of Directors, no signs visible from a neighboring property shall be erected or maintained on any lot except:
- A. Name and address signs;
 - B. Posted political signs. They must comply with the specifications of state (ARS 33-1808) and local laws and the Rules and Regulations of Carriage Manor; *(Revised 11/20/2019)*
 - C. “For Sale” or “For Rent” signs no larger than 12” x 15”. No more than one double-sided sign per lot can be displayed either near the name/number sign at the front of the lot or in a window of the unit. “For Sale” signs must be removed from the property after seven days from close of escrow. *(Revised 4/6/2016)*
 - D. Feather or flutter flags and “Air Dancers” are not allowed. *(Revised 4/6/2016)*
- 12.10 Exterior Speakers. Without written approval of the Board of Directors, no loud or shrill exterior speaker, horn, whistle, bell or other sound device (except security devices used exclusively for security purposes) shall be located, used or placed within the Resort.
- 12.11 Lighting. All high intensity lighting shall be shielded and directed away from streets and the lot of any neighbor.
- 12.12 Clotheslines. No garments, rugs, laundry or similar articles may be visible from the front of a resident vehicle or hung/suspended from an exterior clothesline. Clotheslines are prohibited. *(Revised 12/12/07)*
- 12.13 Reflective Materials. No reflective materials, including, but not limited to, aluminum foil, aluminum-covered materials, reflective screens or glass, mirrors or similar materials shall be installed or placed on the outside or within the inside of any window of a residence or vehicle.
- 12.14 Contractor Insurance. Anyone doing business within the Resort should have liability insurance. It is the LOT OWNERS responsibility to assure his contractor or vendor has proper insurance.
- 12.15 Contractors & Owners Hours of Work. Except for emergencies approved by the Security Chief, the time limit for contractors and owners working in the park shall be as follows:
Monday – Saturday contractors and owners will be permitted to work in the park between 7:00 a.m. and 5:00 p.m. only.
Except for emergencies approved by the Security Chief, no contractors are allowed in the park, and no owner shall perform work on their property on the following holidays: New Year’s Day, Memorial Day, Independence Day, Labor Day, Thanksgiving Day, and Christmas Day. Carriage Manor time limits for owners apply only to the exterior portion of their property. *(Revised 10/18/2023)*

12.16 Trash Disposal and Dumpster Use (Adopted 2/21/2024)

- a. Large branches, limbs or brush must be no longer than 24 inches and 12 inches in diameter to be placed in dumpster.
- b. Cardboard boxes must be emptied and broken down flat before disposing in the dumpster or left at the curb for regularly scheduled trash pickup.
- c. Furniture/bulk items, e.g. couches, chairs, mattresses, box springs, tables, bookcases, desks, floor rugs, carpets may not be placed in the dumpster or left in the surrounding area.
- d. Appliance items, e.g. toilets, sinks, water heaters, showers, tubs, stoves, refrigerators, microwaves, televisions, or air conditioners may not be placed in the dumpster or left in the surrounding area.
- e. Construction waste and dirt are not allowed. This rule applies to residents, handypersons and contractors.
- f. Hazardous materials, e.g. batteries, chemicals, oil, tires and flammable materials may not be placed in the dumpster or left in the surrounding area.
- g. Paint cans are not allowed unless open and dry.
- h. Dumping is not allowed by non-residents or guests.
- i. No salvaging or dumpster diving.
- j. Trash level cannot exceed dumpster height. Dumping not allowed when dumpster trash level is full. Do not dump items in the surrounding area.
- k. Unattended parking is not allowed in the dumpster area.
- l. Trash is picked up from each lot twice weekly. If boxes are not broken down flat, they will not be picked up. Place trash on curb by 8 AM.
- m. The area will be under 24-hour surveillance and violators will be fined.
- n. Enforcement and adjudication procedures for Part 12, 12.16 Trash Disposal and Dumpster Use are listed in Part 15 of the Rules and Regulations for Carriage Manor RV Resort.

\$100 for the first violation and will double each occurrence for subsequent violations up to a maximum of \$2,500. Remove from this area and it gets added to Part 15 as a separate violation Trash Disposal and Dumpster Use. *(Adopted 2/21/2024)*

12.17 Charge to Owners for Individual Maintenance Service. The rate charged to individual owners for work done by our maintenance staff is \$50.00 per hour per man and \$85.00 per hour tractor and \$50.00 per hour for ground spot man. Minimum 1 hour. *(Revised 10/10/07)*

12.18 Citrus Trees. All fruit must be removed from citrus trees by May 1st annually. Fines will begin to be assessed 10 days after May 1st. *(Revised 4/9/2014)*

- 12.19 Rental Properties. All rental contracts require a 3rd Party Agreement to be on file with the Administrative Office with a \$25.00 processing fee due from owner. (Adopted 12/19/2018)

PART 13 **Activities**

- 13.1 Commercial Use. No Resort facility or equipment shall be used to produce any product for commercial sale outside of the Resort, nor shall any profit be made from the sale of such products.
- 13.2 Profits. All profits from any activity made by any group or club conducted on the Resort premises are recommended to be spent only to enhance the Resort for, but not limited to, repair, maintenance, replacement and additional equipment.
- 13.3 Nuisance. No person may pursue any hobby or business within the Resort which may in any way create a nuisance or cause a disturbance to others contrary to the limits imposed by the Covenants, Conditions and Restrictions ("CC&R's"), Bylaws, or these Rules and Regulations, nor in any way be harmful, dangerous or unsafe to the health, safety or welfare of any person or property within the Resort as determined by the Board of Directors, nor be in violation of any federal, state, county or city law, code or ordinance.
- 13.4 Patio Sales. Patio Sales are considered to be a business, therefore will not be permitted within the resort (Reference Rules and Regulations 12.3 and 13.3). The exception to this rule will be the semi-annual resort wide Patio Sale events.

PART 14 **Resort Employees**

- 14.1 Employee Tasks. Resort employees have been hired for the benefit of all residents of the Resort and are prohibited from performing work tasks for any individual during regular working hours except in emergencies or as specifically authorized or directed by management.
- 14.2 Employee Abuse. Abuse of employees by residents is prohibited, including any physical or verbal harassment, intimidation, innuendo or other abuse, specifically including any of the foregoing relating to racial, sexual, job performance or employment matters. In the event of a violation of this rule, all remedies under the governing documents shall be available to the Association, including enforcement as an "Other Violation" pursuant to Section 15.2B of the Rules and Regulations.

PART 15
Enforcement

15.1 CC&R's. The Association, its employees, clubs or any owner shall have the right, but not the obligation, to enforce any current rule or regulation as herein before listed and posted. Any action undertaken or process of complaint initiated shall be in accordance with the procedures listed in the current CC&R's under the title of "Enforcement". (Revised 11/15/2017)

15.2 Fine Assessments.

A. Violation Review Procedure

(1) Any grievance or request for review of a violation of Carriage Manor governing documents, after having been properly filed regarding B. #3 below, may be requested by the person or club served the notice of violation (hereinafter referred to as the "violator"), to be reviewed:

- a) Privately, before a panel of three members of the Board of Directors, assigned by the Board, at a date, time and place set by the Board with a provision for a delay by the person requesting the review. Any and all witnesses directly involved with or in the violation may be requested to be present to give relevant factual testimony or evidence. Hearsay testimony shall not be allowed nor considered. In event the review arises from a violation of the Architectural Guidelines, a representative of the Architectural Review Committee (ARC) may be requested by the Board to be present to give or produce relevant factual testimony or other appropriate evidence. One member of the panel shall be assigned by the Board to chair the proceedings; or,
- b) The violator may request the review be conducted before the entire Board of Directors at a regularly scheduled meeting of the Board.

(2) If the review is conducted before a panel of three (3) members of the Board of Directors:

- a) Representation by legal counsel should not be necessary but if the violator requests to be represented, the Association has the option of like representation;
- b) The violation including all pertinent information, shall be reviewed by the panel;
- c) The violator shall be requested to give his/her testimony and produce other relevant evidence before the panel;
- d) Any other witnesses, having first hand, factual information in reference to the violation shall be requested to speak before the panel;
- e) The review shall at all times be conducted and controlled by the Review Chairman and be reasonably informal;
- f) There shall be no taping of the Review either audio or visual;
- g) After all testimony has been heard and evidence produced,

- the Chairman shall call the Review closed; and
- h) The panel shall immediately thereafter, in private chambers, reach a decision and direct their conclusion to the Board of Directors for its review at the next regularly scheduled meeting of the Board. The Board shall put the item on the agenda to briefly discuss the Review and the decision by the panel and render judgment. A majority vote shall be final.
- (3) If the Review is conducted directly before the entire Board of Directors at a regularly scheduled Meeting:
- a) A “Request To Address The Board” form shall be properly completed and filed by the violator;
 - b) At the proper time on the agenda, the violator and any other witnesses having first hand, factual knowledge of the violation and a representative of the ARC, if requested by the Board, shall give relevant testimony or produce other appropriate evidence pertinent to the violation; and
 - c) The Board shall render its decision as soon as possible. A majority vote shall be final.
- B. Enforcement of these Rules and Regulations, CC&R’s, and the Design Guidelines for Carriage Manor R.V. Resort will be accomplished by the following Assessments which may be levied by the Board of Directors. (Revised 11/15/2017)

	First Offense*	Continued Offense
Speeding	\$25.00	\$50.00
Nuisance	\$25.00	\$50.00
Pets	\$25.00	*See Note 1 on next page
Parking	\$50.00	*See Note 1 on next page
Signs	\$50.00	*See Note 1 on next page
Landscaping	\$50.00	\$100.00
Appearance	\$50.00	\$100.00
Design/Construction	\$100.00	\$500.00
Trash Disposal/Dumpster Use	\$100.00	*See Note 1 on next page
Business/Soliciting	\$250.00	\$500.00
Leasing June-August	\$1,000.00	
Owning Excess Lots	\$1,000.00	\$1,000.00/mo. (until a signed sale contract is submitted to HOA)

*Other Violation Assessment set by Board of Directors not to exceed \$500.00 mo.

- * Fine Note:
1. Continuing violation of Parking, Sign Rules or Pets will result in the doubling of the fine each month to a maximum of \$2,500.00. (Example: \$100, \$200, \$400, \$800, \$1,600, etc.)
 2. Flagrant violation by Renters, Guests and Visitors will be sufficient reason for their being asked to leave the Resort.
 3. Grievances arising from or appeal of any enforcement Action and/or Assessment must be addressed and dated in writing to the Board of Directors of the Carriage Manor R.V. Resort Association for review within 5 days of receipt of the violation notification. Decisions of the Board are final in all cases.

PART 16

Standing committees of Carriage Manor Resort

16.1 Committees. The Board of Directors shall appoint members to the following standing committees of Carriage Manor Resort:

- Architectural Review Committee
- Budget and Finance Committee
- Governing Document Review Committee
- Long Range Planning Committee
- Nominating and Election Committee
- Welcome Committee

Appointments to a standing committee are made based on information provided by the individual on the form “Application to serve on a Carriage Manor Committee” and additional information provided by the Board of Directors and committee members.

Committee members should be available either in person or electronically throughout the year. **(Revised 2/26/2024)**

Committee meetings are open to members of the Association.

Committees will select their chairperson and a secretary responsible for submitting a monthly report of committee actions to the Board member serving as the liaison. They will exercise confidentiality when appropriate regarding the work of their committee. They may be removed with or without cause by the Board of Directors.

Committee Reports will be submitted to the Board President the Friday before all Board of Director Work Sessions. **(Added 2/26/2024)**

- *Architectural Review Committee*. This committee shall be comprised of four (4) to seven (7) owners, appointed for a term of two (2) years and eligible for reappointment for three (3) consecutive terms.

In compliance with Arizona State Law, the committee chairperson will be the Board of Directors member appointed as liaison.

The committee will implement the directives outlined in Part 10 of the Conditions, Covenants and Restrictions (CC and R's) for Carriage Manor Resort and the Design Guidelines document.

The committee will review architectural variances with recommendation of approval or denial to the Board of Directors.
(Revised 9/17/2025)

- *Budget and Finance Committee*. This committee shall be comprised of three (3) owners with accounting or business experience appointed for a term of two (2) years and eligible for reappointment for two (2) consecutive terms.

The treasurer of the Board of Directors shall be both liaison to the Board of Directors and a voting member of this committee.

The duties of this committee are to assist the treasurer as required under Bylaw 7.8d.

In addition, this committee will review the Reserve Study, recommend funding levels to the Reserve, Capital Improvement and Operating budgets for Board of Directors consideration in the annual budgeting process. This committee shall review or conduct club audits on an annual basis.

- *Governing Documents Review Committee*. The committee shall be comprised of three (3) owners, appointed to a term of two (2) years and eligible for reappointment for two (2) consecutive terms.

At the request of the Board of Directors, this committee will review and propose updates to the Board of Directors for the governing documents of Carriage Manor Resort. These include The Bylaws, Covenants, Conditions and Restrictions, the Architectural Guidelines, Design Guidelines and the Rules and Regulations documents.

The committee will review variance requests of CC&R and Rules and Regulations with recommendations of approval or denial to the Board of Directors. (Revised 9/17/2025)

- *Long Range Planning Committee*. The committee shall be comprised of five (5) to seven (7) owners, for a term of two (2) years, and eligible for reappointment for two (2) consecutive terms. The duties of this committee are to assist in the implementation of Part 12.1 of The Bylaws of Carriage Manor Resort, assist the CM Board of Directors in the development and update as appropriate the Carriage Manor RV Resort Strategic Plan, assist in the assessment and management of projects falling under Part 8.1.A of the Restated Declaration of Covenants, Conditions and Restrictions for Carriage Manor RV Resort when requested by the Board of Directors.
- *Nomination and Election Committee*. This committee shall be comprised of six (6) owners, appointed by the Board of Directors for a term of two (2) years and eligible for reappointment for two (2) consecutive terms.

One member of the committee shall be a member of the Board of Directors not running for reelection. The other members shall not be current members of the Board of Directors.

The committee will assist in coordinating and establishing Carriage Manor's election processes. Additionally, it is responsible for the Board of Directors nominating process by presenting nominations, preparing and distributing a brief biographical sketch of nominees prior to the election, and facilitating oral presentations by the candidates. The committee's nominating process is not exclusive. (Adopted 12/13/2017)

- *Welcome Committee*. This committee shall be comprised of three (3) to five (5) owners, appointed for a two (2) year term and eligible for reappointment for three (3) consecutive terms.

The committee will assist with meeting and greeting new Carriage Manor owners and renters by facilitating orientation, face-to-face meeting opportunities, and questions-and-answer sessions.